

AVM Universal Linear Actuators

For controllers with continuous output (0...10 V) or switched output (2- or 3-point control). For operating through valves or three-way valves of the VXN, BXN series.

Choice of characteristic (linear/equal percentage) can be set on the actuator. Two-part housing of fire-retardant plastic, lower part in black, upper part in yellow. With stepping motor, electronic control unit and maintenance-free gears.

Fixing bracket of plastic and cap nut of brass for fitting the valve. Assembly with the valve is practically automatic. Direction of operation can be changed at the cable.

Electronic, torque-based cut-out via stops on either the actuator or the valve; automatic adaptation to the valve's stroke. Coding switches for selecting characteristic and running time.

Disengageable gears for positioning the valve by hand (no. 6 Allen key). Power cable 1.2 m long, 5 · 0.5 mm². Fitting position: anywhere from vertical to horizontal, but not upside down.



Model Types	Model	Description
	AVM-250-UNI	AVM-250-UNI 250Nm Linear Universal Actuator
	AVM-500-UNI	AVM-500-UNI 500Nm Linear Universal Actuator
Technical Data	Power Supply	24Vac 50/60 Hz +/-20% 50..60Hz
	Power Consumption - running	30s – 5VA 60s – 7VA 120s – 5VA
	Power Consumption - standstill	0.5VA
	Running Time	35 / 65 / 130 (AVM-250-UNI) 60 / 120 (AVM-500-UNI)
	Stroke	8mm
	Torque	250Nm (AVM-250-UNI) 500Nm (AVM-500-UNI)
	Response Time	200ms
	Max. Operating Temperature	100°C at valve
	Ambient Temperature Limits	-10..55°C
	Ambient Humidity	5 ... 95%rh non-condensing
	Degree of Protection	IP 54 as per EN 60529
	Protection Class	III as per EN 60730 II as per EN 60730
	Noise while Running	< 30dB(A)
	Weight	0.7 kg
Accessories	Model	Description
	ASM-SK-5001	ASM-SK-5001 Single Auxiliary Contacts
	ASM-SK-0001	ASM-SK-0001 Double Auxiliary Change-Over Contacts

- Operation** Depending on how it is connected (see wiring diagram), the actuator can be used as a continuous 0...10 V, as a 2-point (open/close) or as a 3-point drive (open/stop/close) with intermediate position.
- The running time can be matched to requirements using switches S1 and S2. The characteristic (equal-percentage or linear) can be selected via switch S3.
- Manual adjustment is performed by disengaging the gears (sliding switch next to the power cable) and simultaneously turning, using an Allen key in the insert on the upper part of the drive. Eight mm of stroke is attained with 1½ turns.
- Note:** After manual adjustment, re-set the sliding switch (engage the gears).
- Connected as a 2-point actuator** Open/close activation can be effected via two wires. Power is applied to the drive via the blue and the black wires. On connecting power to the brown wire (2a), the valve's control passage opens. When power is switched off, the drive goes to the opposite end position and closes the valve. The unused red and grey wires should not be connected, nor should they come into contact with other wires. We recommend that you insulate them.
- Connected as a 3-point control unit** By connecting power to the wires (2a or 2b), the valve can be moved to any position. The coupling rod extends and opens the valve if power is applied to the brown wire (2a). It retracts and closes the valve if power is applied to the blue (1) and the black (2b) wires.
- In the end positions (on hitting a stop in the valve or reaching the maximum stroke) or in the event of an overload, the electronic motor cut-off responds (no end switches). The direction of the stroke can be changed by swapping the power-supply wires over. The unused red and grey wires should not be connected, nor should they come into contact with other wires. We recommend that you insulate them.
- Connections for control voltage 0...10V** The integrated positioner controls the drive as a function of the controller's positioning signal y .
- Direction of operation 1 (mains power at brown wire, internal connection 2a): the coupling rod extends and opens the valve (control passage) as the positioning signal rises.
 - Direction of operation 2 (mains power at black wire, internal connection 2b): the coupling rod retracts and closes the valve (control passage) as the positioning signal rises.
- The starting point and the control span are both pre-set.
- There is a split-range unit available (as an accessory) for setting partial ranges.
- After manual adjustment or in the event of a power failure for longer than 5 minutes, the drive readjusts itself automatically (always with a running time of 65 or 60 seconds).
- After power has been applied, the stepping motor moves to the upper stop in the valve, thereby determining the closed position. Depending on the control voltage, any stroke between 0 and 8 mm can then be obtained. Thanks to the electronics unit, no steps are lost, and the drive needs no periodical re-adjustment. Parallel operation of more than one drive of the same type is guaranteed.
- The feedback signal $y_0 = 0...10\text{ V}$ corresponds to the effective stroke of 0 to 8 mm.
- If the control signal (0...10 V) is interrupted and direction of operation 1 is set, the valve opens fully. To close the valve, a resistance of 10 k Ω must be connected permanently between terminals 1 and 3. The valve's characteristic can be selected using the coding switch. The equal-percentage characteristic can be created only if the drive is used as a continuous drive. Other switches enable the running times to be set. These can be applied irrespective of whether the 2-point, 3-point or the continuous function has been chosen.

Coding Switch

AVM-250 8mm	AVM-500 8mm	S1	S2	S3
130s	120s	off	on	-
130s	120s	on	on	-
65s	60s	on	off	-
35s	60s	off	off	-
Initialization on			-	on
Initialization off				off
Ex-works position		on	on	on

Installation Notes

The ingress of condensate, drops of water etc. along the valve spindle and into the drive should be prevented. Should not be fitted upside down.

The assembly of drive and valve is done by fitting and tightening the cap nut without further adjustment; no tools should be used. The valve spindle and the drive spindle are coupled together automatically, either by using the manual adjustment facility or by applying power. To disassemble, the drive and valve spindles should be loosened first, then the cap nut.

The drive is supplied ex works in the middle position.

The combination of stepping motor and electronics allows several actuators of the same SUT type to be run in parallel.

The following accessories can be fitted to each actuator: one set of auxiliary contacts.

The coding switches are accessible via an opening with black lid in the housing cover.

The auxiliary contacts should be screwed onto the drive's top cover. Before the mechanical connection can be established, the indicator knob should be removed. A new indicator is then visible on the lid of the auxiliary contacts.

Note: The housing should not be opened.

The upper part of the housing, with the lid, indicator knob and the cap, contains the stepping motor and the electronic control unit. The lower part contains the maintenance-free gears.

Auxiliary change-over contacts

Switch rating: max. 230 V a.c.; min. current 20 mA at 20 V

Switch rating: max. 4...30 V d.c.; min. current 1...100mA

Wiring Terminals



Note: The electric installation, assembly, device connection and commissioning may only be carried out by qualified professionals! Read the notes about the use and torque requirements of the damper actuators.

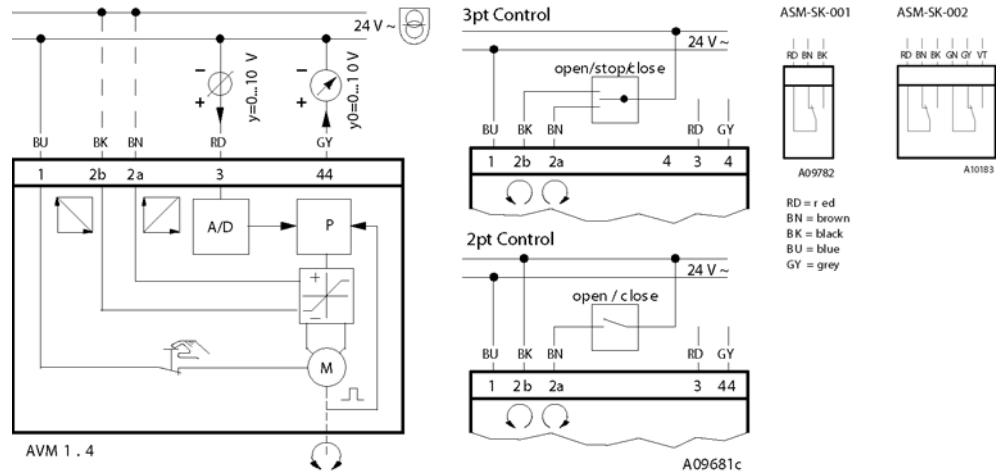

Dimensions

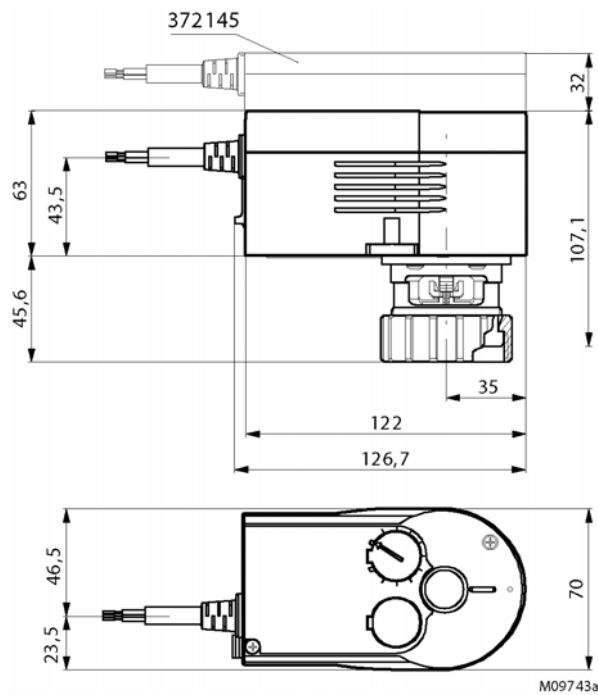

All dimensions are in mm.