

HRP21 Optimiser/Compensator

The HRP21 is specifically designed for the regulation, control, optimisation, and monitoring of heating systems. This controller is ideal for applications where heating systems involve boiler regulation or the control of non-storage heat exchangers as a primary source in addition to the main heating circuit, where the loop may require remote operation, Domestic Hot Water control, and an extremely easy to use interface for the end user.

The controller also incorporates Pump Auto changeover options, legionella protection for the DHWS Storage Calorifier, Automated Summer/Winter Time Changeover, Leap Year Complaint calendars, Full Configuration Back Up and restore options, and 16 Pre-defined application Macros that will control without intervention.

In setting the plant macros, the HRP is completely configured, the accompanying HRP software menus are set, the parameters are configured, and the input and output signals are assigned. The user is guided through the settings via a plaintext menu system. Reading and writing of the data takes place in 3 priority levels accessed through individual codes.

Eight HRP/LRP controllers can be administrated on each of the employed HRP/LRP Bus Systems, each LAN can operate over a distance of 1000 m. Communication to all bus participants can



take place between each controller. Additionally remote control of one HRP/LRP is possible from any other HRP/LRP connected on the same LAN. Important plant values and information can also be shared to facilitate plant integration directly between controllers without the need of a front end.

For wide area networks, the separated plants can utilise data transmission via modem over the public telephone network. This can take place with direct connection of the modem to the HRP controller.

HRP21-S has the same functionality as the HRP21 but is not networkable to other LRP/HRP controllers.

Model Types

Model	Description
HRP21	HRP21 Optimiser/compensator with 0...10Vdc output for valve actuator
HRP21-S	HRP21-S Heating Optimiser/Compensator without CAN Bus controller

Features

- Designed for the regulation, control, optimisation and monitoring of heating plants with boiler regulation or district heating plants.
- Bus and modem can be connected.
- Dual control of a District Heating non-storage plate heat exchanger and the compensated circuit is possible in addition to DHWS.
- One-knob operation and a graphic, illuminated display for the input and query of all DDC data.
- Simple extension of the basic functions by means of the HRP software menus such as Optimisation, Room Correction, Set Point Limitation, Stand by, Boiler Regulation, Domestic Hot Water tank control, Circulation Pump, Operating Hours Counter, Heat Counter, Pump Blocking Protection, Legionella Protection.
- 16 Pre-programmed applications
- Remote control features and easy to set up remote overrides

In setting the plant macros, the HRP is completely configured, the accompanying HRP software menus are set, the parameters are configured, and the input and output signals are assigned. The user is easily guided through the operating system with a plaintext menu.

- Input and query of the data in 3 priority levels can be accessed with code keys.
- Three independent Time Schedules and additional single shot annual program.
- Holiday Scheduler
- Trend value acquisition and display of important plant values.
- Upto 8 HRPs can be administrated by means of the HRP LRP Bus. System Communication of all bus participants among each other with queries or modifying all parameters that are an integrated part of the HRP. HRP diagnostics graphically display active members and permit sensor sharing.

A direct connection to the BMS with the RS232 interface is available. For widely separated plants Data transmission for BMS via a modem over the public telephone network is also available.

Technical Data	Inputs and outputs	5 digital inputs BE	Zero-voltage contact Two of these are impulse inputs 20Hz
		4 digital outputs BA	Relay contacts zero-voltage max. 6 (3)A; 250Vac
		1 analogue output AA for servo device	0...10V; 5mA; 24Vac
		6 analogue inputs AE	KP10, active measuring element
		1 analogue input AE	0...10V continuous (remote setpoint setting)
		Analogue/digital conversion	10 Bit
	Interfaces	Serial RS232	Building Management System BMS, modem
	Bus connection (HRP21 only)	CAN Bus	Maximum 8 HRP/LRP to one bus system
	Power Supply	230Vac ±10%; 50...60Hz; 12VA; 52mA	
	Nominal voltage	HRP21: 12VA, current requirements 78mA at 230Vac	
	Displays	Graphics display with backlighting LED for error messages and manual operation	
	Diagnosis jack	Diagnosis/data backup	
	Operation HRP21	One rotating knob, selection button [SET], escape button [ESC]	
	Fuse	Fuse S1 6A (T) for external switching Fuse S2 630mA (T) for electronics Accessible from the rear	
	Processor	80C592	
	Memory	32kByte RAM; 240kByte Flash PROM	
	Operating system	Multi-tasking	
	Mains failure data backup	Lithium battery, unlimited	
	Degree of electrical protection	IP 20	
	Operating temperature	0...45°C	
	Environmental humidity	In service: 20-80%rh, non-condensing Out of service 5-90%rh, non-condensing	
	Housing	Plastic housing fire-resistant	
	Measurements	HRP21: 198.5mm width x 110mm height x 85mm depth (with wall console W/HRP 15mm deeper)	
	Front panel cut-out	200.4mm x 112.0mm	
	Weight	1.2kg	
	Agency Approvals	CE	

Inputs & Outputs

	Details
Temperature inputs	6 x analogue inputs for active measuring element type KP10
Analogue inputs	1 x analogue input 0...10V
Digital inputs	5 x binary inputs
Actuator Outputs	1 x 0-10Vdc output for valve actuator
Digital Outputs	4 x 230V or zero-voltage, 3A for pumps, boilers or plate exchanger
Power Supply	Mains 230Vac ±10% 50...60Hz

Wiring Diagram

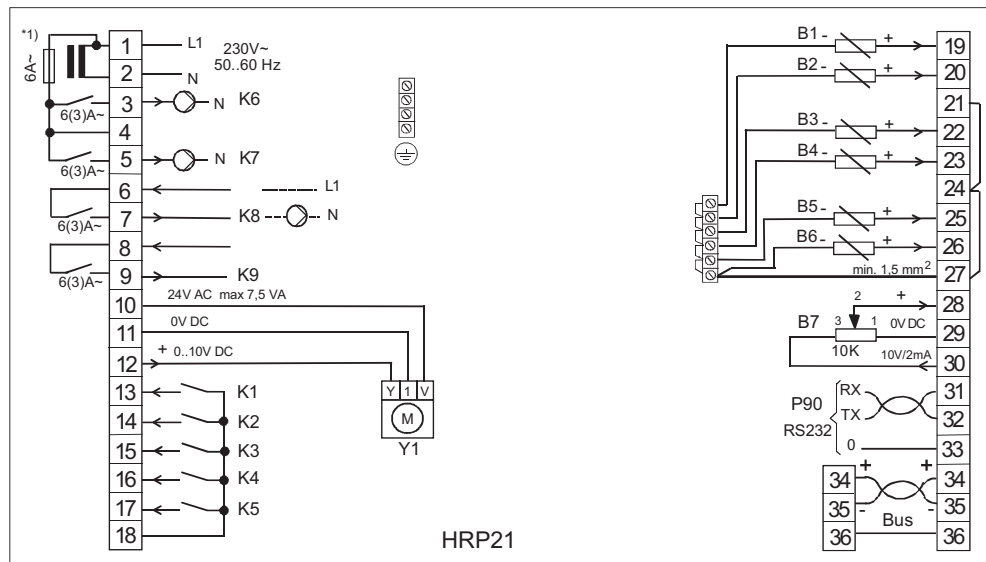

*1) By removing the fuse S1 (6A(T)), the outputs K6 and K7 become zero-voltage.

Notice:

If the supply voltage 24V~ for the servodrives is made available with an external transformer, then no connection is allowed to the internal 24V~ of the HRP21.

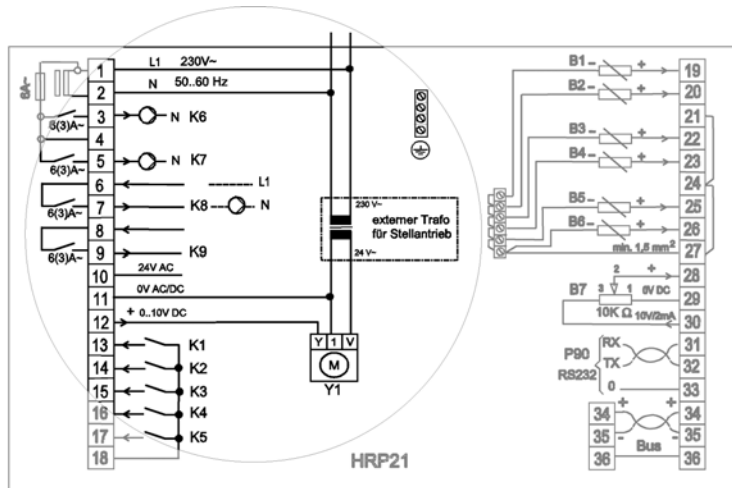

Temperature Ranges

Please note the sensor ranges of the HRP when dealing with the **trend curves and the outside temperature assignment**.

The sensors are polarity sensitive.

Screened cable should be used.

For temperatures outside these limits, the value is represented as " " (invalid)!

Input Address	Name	Lower Limit	Upper Limit	Input Type	Units
b1	Outside Air Temperature	-50.0	70.0	KP10	°C
b2	Space Air Temperature	0.0	120.0	KP10	°C
b3	Compensated Flow Temp	0.0	120.0	KP10	°C
b4	Sensor 4	0.0	120.0	KP10	°C
b5	Sensor 5	0.0	120.0	KP10	°C
b6	Sensor 6	0.0	120.0	KP10	°C
b7	Sensor 7	0.0	100.0	0-10V	% ^a

a. b7 is scalable between -1000.0 and +1000.0