

Table 2: Summary of configuration commands.

COMMAND	DESCRIPTION	EXAMPLE	
TURNON	Activates an output.	TURNON_OUT1	Activates OUT1.
TURNOFF	Deactivates an output.	TURNOFF_OUT2	Deactivates OUT2.
REGULATE	Enables the temperature regulation function.	REGULATE_22_10	Regulates heating on OUT1 at 22°C for 10 hours.
STATUS	Requests the status of inputs e outputs.	STATUS	An SMS message reporting the system status will be returned.
ANTIFROST	Enables the antifrost function.	ANTIFROST_4	OUT1 will be switched on in the event that the temperature falls below 4°C.
SETREPORT	Configures the sending of confirmation messages.	SETREPORT_ON	Enables the sending of confirmation messages.
ADD	Adds a contact.	ADD_MARIO_+391234	Adds MARIO and the respective phone number to the contact list.
REMOVE	Deletes a contact.	REMOVE_+3912345678	Delete the contact with the phone number indicated.
CONTACT	Requests the contents of the contact list.	CONTACT	An SMS message containing the list of contacts will be returned.
NEWNAME	Sets an alternative name for an input or output.	NEWNAME_OUT1_BURNER	In commands BURNER can be used in the place of OUT1.
ALARM	Configures an alarm as enabled or disabled.	ALARM_IN1_OPEN_3_s	An alarm will be generated if input IN1 opens for 3 seconds.
ALARM	Disables alarm IN1.	ALARM_IN1_DISABLE	Input IN1 will no longer generate alarm messages.
ALARM	Requests the current alarm configuration.	ALARM	An SMS message with the current alarm configuration will be returned.
MESSAGE	Sets a personalised alarm message.	MESSAGE_IN1_PUMP	"PUMP" becomes the text of the SMS message that will be sent on occurrence of the alarm.
CREDIT	Enables the credit function.	CREDIT_456	Sets a remaining credit of 456 SMS messages.
SETPSW	Changes the password.	123456_SETPSW_PIPPO	"PIPP0" becomes the new password.
DEFAULT	Restores factory default configuration.	DEFAULT	Return to the factory configuration with password "123456".
VERSION	Requests the device firmware version.	VERSION	An SMS specifying the firmware version of the interface will be sent.
LANGUAGE	Sets the default language.	LANGUAGE_IT	Italian is set as the default language.
CALIBRATE	Calibrates room temperature readings.	CALIBRATE_-3,0	An offset value of 3°C will be subtracted from the room temperature reading.

In view of its commitment to continuous product development, the manufacturer reserves the right to change technical and performance specifications without notice. Consumers are protected by a warranty against product nonconformities in accordance with European Directive 1999/44/EC and the manufacturer's warranty policy. The complete text of the warranty is available from the dealer on request.

# ITP R32 100 OSE



## GSM TELEPHONE INTERFACE

- Control via SMS of 2 outputs with SPDT power relay
- Two digital inputs with option of sending SMS alarm messages
- Room temperature reading via an external sensor
- Operation in heating mode
- Antifrost function
- High level of reliability thanks to automatic re-registration every 24 hours and automatic reset every 3 days
- Visual indication of the status of the two outputs and manual changeover by means of pushbuttons

Via Prodocimo, 30  
I-36061 BASSANO DEL GRAPPA (VI)  
- ITALY -  
Tel.: +39.0424.567842  
Fax.: +39.0424.567849  
<http://www.seitron.it>  
e-mail: [info@seitron.it](mailto:info@seitron.it)

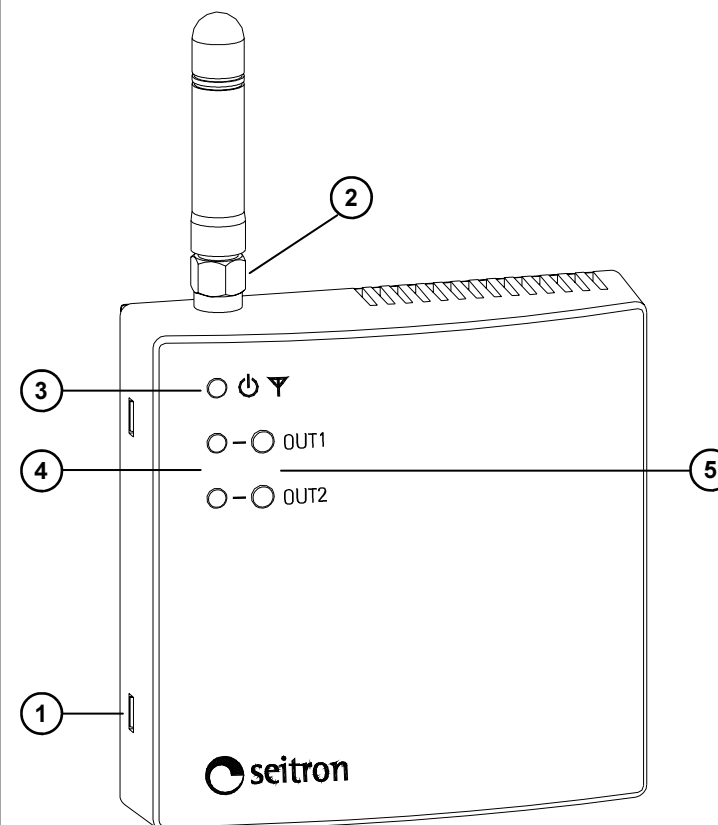

Fig. 1: Exterior appearance.

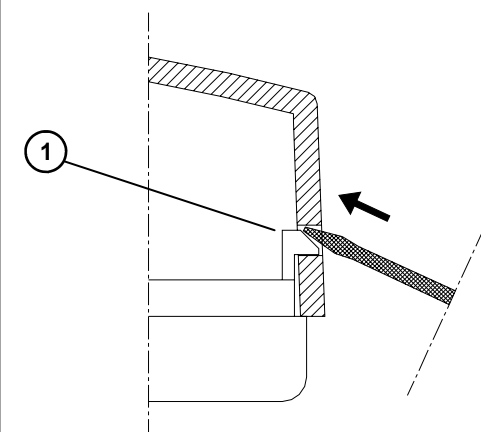

Fig. 2: Removal of cover.

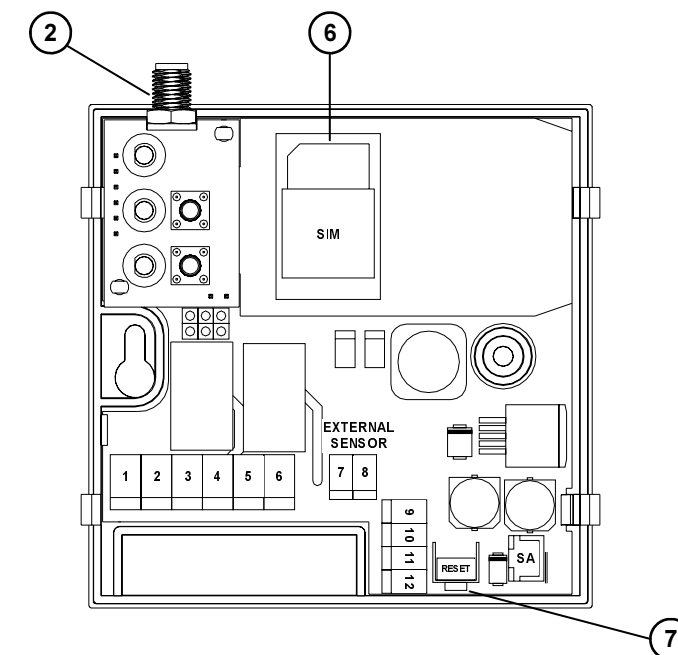

Fig. 3: Internal layout of components.

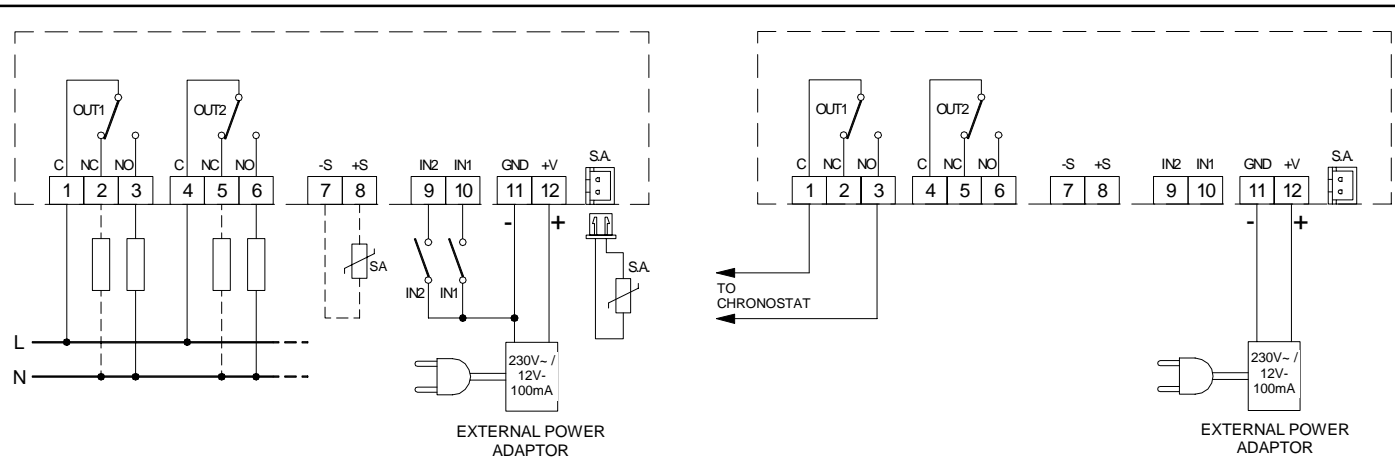

Fig. 4: Connection diagram.

Fig. 5: Example of connection to a timer thermostat.

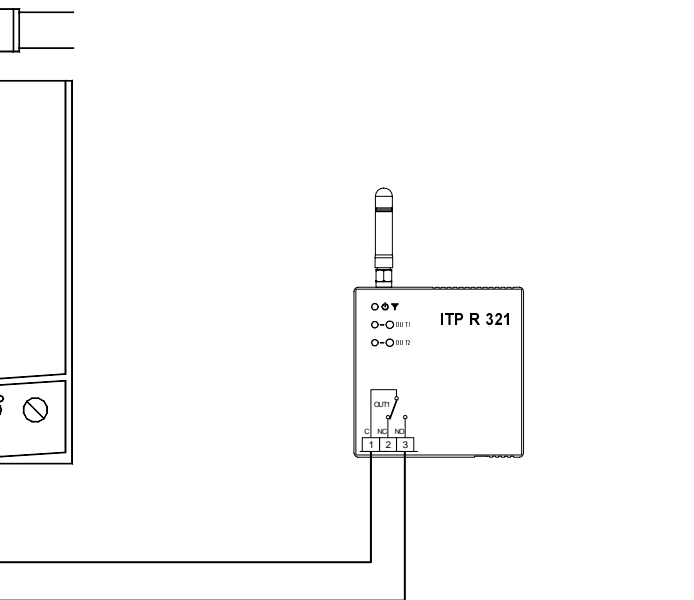

Fig. 6: Example of the telephone interface connected in series with a thermostat.

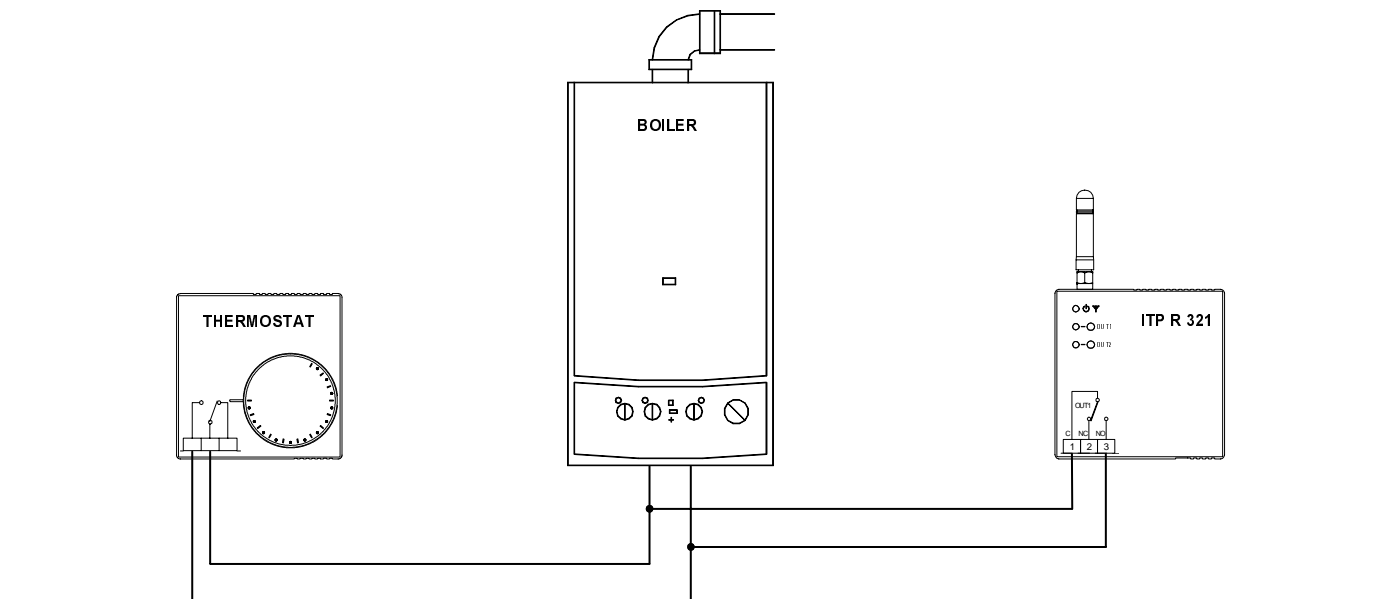

Fig. 7: Example of the telephone interface connected in parallel with a thermostat.

whose status is acquired by the interface. It is possible to connect any electrical contact to these inputs, as indicated in the diagram. However, it is important to use a voltage free contact, i.e. one connected only to the interface and not to other electrical equipment.

Terminals 11 and 12 are the inputs to which you must connect the 230V~/12V power adaptor (supplied); connect the positive wire, usually marked with a white stripe, to terminal 12.

If you want to connect the telephone interface to a timer thermostat with an input dedicated to the interface, connect the 2 wires originating from the timer thermostat as shown in the diagram in Fig. 5. If you want to control a system remotely using a simple thermostat or timer thermostat not provided with an input dedicated to the telephone interface, it is possible to connect the interface in 2 ways, which result in slightly different operating modes:

**Connection in series** (Fig. 6): OUT1 must be in the ON status in order to turn on the burner and permit regulation of the temperature via the thermostat. To disable the temperature regulation function, you must turn OUT1 OFF. The thermostat setpoint should always be left on the "comfort" temperature. If you want to use the antifrost function, you must enable it from the interface by giving the ANTIFROST command rather than switching OUT1 to OFF.

In this case it is necessary to install the temperature sensor in the room whose temperature you wish to regulate.

**Connection in parallel** (Fig. 7): OUT1 must be in the OFF status in order to regulate temperature via the thermostat. To disable the regulation function either turn off the thermostat or turn the setpoint adjustment dial to minimum. To turn it on remotely, send the 'REGULATE' command to the interface, which will regulate the temperature to the desired value. When you want to go back to regulating the temperature with the thermostat, you must turn it on or raise the setpoint and switch OUT1 of the interface to OFF. If desired, the antifrost function can be obtained by means of the thermostat, for example by turning the setpoint adjustment dial to minimum. Alternatively you can enable it through the telephone interface by giving the ANTIFROST command; in this case it is necessary to install the temperature sensor in the room whose temperature you wish to regulate.

#### TECHNICAL FEATURES

Power supply:	12V= (10 .. 16 V=)
Electrical input:	1,3W Max
Frequency:	900 - 1800 MHz Dual Band
Antenna type:	Stylus, SMA screw connector
Range of adjustment:	0.0 .. 32.0 °C
Antifrost range:	0.0 .. 18.0 °C
Measuring range:	-20.0 .. 55.0 °C
Sensor type:	NTC 4.7K @25°C ±1%
Precision:	± 1.0°C
Resolution:	0.1°C
Regulation hysteresis:	0.5 °C
Alarm hysteresis:	1.0 °C (for 60 sec)
External sensor:	Code STL NBG Y100
Length of ext. sensor wires:	3 m MAX
Contact rating:	2 x 3A @ 250V~ SPDT
Digital inputs:	2 voltage free
Analog inputs:	1 for external NTC sensor
Indicators:	2-colour red: on 2-colour green: connected Red OUT1 on: Output 1 enabled Red OUT2 on: Output 2 enabled
Protection rating:	IP 30
Operating temperature:	-20 .. +55 °C
Storage temperature:	-20 .. +55 °C
Humidity limits:	20 .. 80 % RH non-condensing
Enclosure: Material:	ABS V0 self-extinguishing
Enclosure: Colour:	Signal white (RAL 9003)
Dimensions:	85 x 85 x 31 mm (W x H x D)

Weight:	~ 556 gr.
Installation:	Wall mounted
EMC normative references:	EN 55014-1 EN 55014-2
LVD normative references:	EN 60730-1
RTTE normative references :	EN 301 489-1 V1.6.1 EN 301 489-7 V1.3.1 EN 301 511 V9.0.2

#### ⚠ WARNING

- This device has been designed to work complete with a SIM card and antenna. Do not keep the device on for long periods of time if the SIM card or antenna are missing.
- This device is a low power radio transceiver. When switched on, it transmits and receives radiofrequency energy.
- The device may cause interference if operated in proximity to radios, television sets, telephones or electronic equipment in general.
- The device may in turn be subject to interference that can affect its performance.
- Do not position the device in proximity to medical equipment.
- Do not use the device in contact with the human body and do not touch the antenna unless strictly necessary.
- The device works by using a radio signal: no mobile phone operator is able to guarantee a connection at all times.
- To ensure correct regulation of room temperature, it is recommended to install the sensor away from sources of heat, draughts or particularly cold walls (thermal bridges).
- To connect the sensor use cables with a minimum cross-section size of 1.5 mm<sup>2</sup> and maximum length of 25 m. Do not pair the cables in ducts with the mains power lines.
- Connect the device to the mains power supply via an omnipolar switch complying with current regulations and having a contact gap of at least 3 mm in each pole.
- Device installation and electrical connections must be entrusted to qualified personnel and must comply with the laws in force.
- Before making any connections make sure the mains power is disconnected.

Table 1: Factory default settings.

FUNCTION	FACTORY DEFAULT SETTING
Output OUT1	OFF
Output OUT2	OFF
Temperature regulation	OFF
Antifrost function	OFF
Contact	No contact
Output/Input alternative name	OUT1 = BURNER
Alarm TMAX	Disable
Alarm TMIN	Enable to 5.0 °C
Alarm IN1	Close 3 sec disable
Alarm IN2	Close 3 sec disable
Alarm message	Default
Credit function	OFF
Password	123456
Language	Italian
Setreport	ON

In this case an alarm message will be sent if IN1 switches from a closed status to an open one for at least 3 seconds.

Example: **ALARM IN2 CLOSE 10 m**

In this case an alarm message will be sent if IN2 switches from an open status to a closed one for at least 10 minutes.

### MINIMUM TEMPERATURE ALARM

Using this command you can set the minimum room temperature, within a range of -20°C .. +55°C, below which the telephone interface will send the corresponding alarm message.

The command sent to the interface must contain the following information:

**ALARM\_TMIN\_temperature**

Example: **ALARM TMIN 10**

The minimum temperature set in this case is 10°C; the interface will generate an alarm message if the room temperature falls to 10°C or lower.

### MAXIMUM TEMPERATURE ALARM

Using this command you can set the maximum room temperature, within a range of -20°C .. +55°C, above which the telephone interface will send the corresponding alarm message.

**ALARM TMAX 26**

The maximum temperature set in this case is 26°C; the interface will generate an alarm message if the room temperature rises to 26°C or higher.

**Important: Once a temperature alarm has been sent, the temperature must vary by at least 1°C for at least 1 minute in order for a new alarm message to be generated.**

### ENABLING / DISABLING ALARMS

Each alarm may be individually enabled or disabled:

**ALARM\_alarm type\_status**

Alarm type: IN1  
IN2  
TMIN  
TMAX

Status: ENABLE  
DISABLE

Examples: **ALARM IN1 ENABLE**  
**ALARM IN2 DISABLE**  
**ALARM TMIN ENABLE**  
**ALARM TMAX DISABLE**

If you want to know the alarm configuration, it is sufficient to send a message containing the word 'ALARM' (without any accompanying parameter).

The interface will respond with a message like the ones in the examples below:

TMIN 5.0C ENABLE  
TMAX 30.0C ENABLE  
IN1 APERTO 3 s DISABLE  
IN2 CHIUSO 10 m ENABLE  
SETREPORT OFF

The response means:

- " minimum temperature " alarm enabled, with a threshold of 5.0°C;
- " maximum temperature " alarm enabled, with a threshold of 30.0°C;
- alarm when the contact of input IN1 remains open for at least 3 seconds, but the alarm is disabled;
- alarm when the contact of IN2 closes and remains closed for at least 10 minutes, the alarm is enabled;
- the function of responding to each command with an SMS confirmation is disabled (OFF);

When the device leaves the factory all alarms are disabled except for TMIN, which is configured as ENABLED at 5°C.

### Alarm messages

Upon the occurrence of an alarm the interface will send the following warning messages to all enabled users, depending on the type of alarm (DEFAULT):

**ALARM IN1**  
**ALARM IN2**  
**ALARM TMIN**  
**ALARM TMAX**

Using the 'MESSAGE' command you can personalise the alarm messages by defining a new text with a maximum of 60 characters:

**MESSAGE\_IN1\_new message**

**MESSAGE\_IN2\_new message**

**MESSAGE\_TMIN\_new message**

**MESSAGE\_TMAX\_new message**

**For example: MESSAGE IN1 ALARM PUMP**

" PUMP ALARM " becomes the text that will be used for the alarm associated with input IN1.

### DEFAULT: Reset default.

The 'DEFAULT' command resets all parameters to the factory default configuration (see table 1).

**DEFAULT**

### VERSION: Firmware version

On receiving this command the interface will send a message containing the firmware version of the device.

**VERSION**

The response will be of the following type: ITP R 321 Ver.FW 1.0

### LANGUAGE: Language of response messages.

The LANGUAGE command allows you to select the language of the response messages, in the event it is not possible to establish the desired language by means of the command issued, as for example in the case of 'NEWNAME' (used for commands both in Italian and English).

It is possible to select one of the following two languages:  
Italian: **IT**  
English: **EN**

The message sent to the interface must be composed as follows:

to set the Italian language: **LANGUAGE IT**

to set the English language: **LANGUAGE EN**

### RELIABILITY

In typical conditions of use, the telephone interface remains in stand-by for long periods of time, waiting for commands via SMS. During these periods the mobile phone operator may decide to "unregister" the interface due to extended inactivity and cut off GSM communication.

To ensure that the communication link is always maintained active, the interface automatically runs a re-registration cycle every 24 hours. Moreover, a reset cycle is run automatically every 3 days to assure that correct operation is restored even after unforeseen events.

During the reset procedure, the outputs are switched off for several seconds and then returned to their previous status.

Both the output status and configuration are retained also in the event of a mains power failure.

### ELECTRICAL CONNECTIONS

Follow the connection layout shown in Fig. 4.

The changeover contacts of the relays of the two outputs are available at terminals 1 .. 6. The relay contacts are voltage free and it is possible to activate loads as shown in the diagram. An external temperature sensor can be connected either to terminals 7 and 8 or the SA connector.

Terminals 9 and 10 are respectively inputs IN2 and IN1,

### GENERALITIES

This device is a telephone interface capable of switching one or two electric devices on and off from any distance via a GSM mobile phone network. It can be used to control burners, timer thermostats, air conditioning systems and small irrigation systems, etc.

The interface works with a SIM card that is inserted inside it and accepts SMS commands from users memorised in the contact list or password-based commands; all SMS messages received from unrecognised users or containing command errors are ignored and deleted. In addition, in alarm conditions the telephone interface sends brief SMS messages to the phone numbers in the contact list.

The telephone interface can receive commands from a mobile or fixed telephone or another device (computer or alarm system) provided it has the capability of sending SMS messages. By means of simple SMS messages you can command up to two external devices or check the status of the two outputs and two outputs, as well as getting a room temperature reading.

The interface has a non-volatile memory enabling it to retain information about its current status and resume operating in the same status even after a power failure.

Two pushbuttons on the front of the interface allow you to change over the output status manually. The status is visually indicated by two LEDs (OUT 1 and OUT 2).

The two-colour GSM status LED (ϕ Ψ) lets you know at all times whether the interface is connected to GSM network or not and also provides an indication of signal strength.

Advanced functions make it possible to regulate the room temperature, via an external sensor, or protect the interior by means of the antifrost function.

### Glossary

**GSM:** 'Global System for Mobile Communications', an international standard for digital mobile telephony.

**SMS:** 'Short Message Service' permits you to send or receive messages of up to 160 characters using mobile phones or fixed telephones that support this function.

**SIM:** 'Subscriber Identity Module' it is the smart card inserted in each GSM phone and contains the protocols for connecting to the lines of the mobile phone operator, the subscriber's personal data, SMS messages and contact list. It may be in ISO format (the size of a standard credit card) or of the Plug-in type.

### INSTALLATION

To install the device, carry out the following steps:

- Identify the best position for installing the telephone interface, making sure to check that the GSM operator signal strength is good.
- For installation it is necessary to access the internal parts. To open the plastic enclosure, remove the front cover using a small screwdriver to pry the plastic tabs (1). Apply gentle pressure with the screwdriver between the tab and the opening but do not press directly on the tab, as it might break.

A cross-section view of the plastic enclosure is provided in Fig. 2 to illustrate how to use the screwdriver correctly.

- Mount the interface on a wall using two screws, to be inserted in the holes with a distance between centres of 60 mm.

When working with tools in the vicinity of the screw holes, be careful not to damage the internal electronic circuits.

- Insert the SIM card in the telephone interface (6), after suitably preparing it as described in the paragraph: "**PREPARING THE SIM CARD**".

Disconnect the telephone interface from the power supply before inserting or removing the SIM card.

- Make the electrical connections (see paragraph on 'electrical connections').
- Fit the cover back in place: position it on the base, making

sure that the holes match up with the LEDs and press moderately hard until the four plastic tabs (1) snap into place.

- Screw the antenna provided into its connector (2).

### EXTERNAL TEMPERATURE SENSOR

To be able to get a room temperature reading it is necessary to connect an external sensor to the 'SA' connector (Fig. 3) or, alternatively, connect the 2 wires to terminals 7 and 8.

The type of sensor used must be an NTC sensor, 4700 Ohm @ 25°C, with an adequate beta value. Maximum allowed length: 3 metres.

In case of doubt as to the type of sensor to be connected, please contact the manufacturer.

### PREPARING THE SIM CARD

Before placing the SIM card in the telephone interface, you must insert it into a mobile phone and carry out the following steps:

- Deactivate the **PIN CODE** prompt.

*The telephone interface can only work with SIM cards that do not request a PIN code when the device is switched on.*

- Delete all the phone numbers present in the contact list.

*The interface only works with the first 10 numbers stored in the memory; if these locations are already occupied by service numbers, as in the case of a newly purchased SIM card, the interface will not be able to function correctly.*

- If you do not know the phone number associated with the SIM CARD, make a call to another telephone.

### OPERATION

#### Mechanical description

Fig. 1 shows the exterior appearance of the telephone interface.

#### GSM status LED ϕ Ψ (3)

This is a two-colour LED that indicates the device operating status:

**Red:** when this LED is lit, it means that one of the following conditions exists:

- The device is powered and in the initialisation and GSM network registration phase. In this status it cannot manage commands via SMS.
- There are problems with the SIM card, or the card is not inserted.
- There is no signal or the antenna is missing; there is no communication with the mobile phone operator.

*Generally speaking, the red LED indicates that the interface is not able to receive or transmit SMS messages.*

**Green:** the interface is connected to the GSM network and is ready to receive commands via SMS.

The type of blink indicates the strength of the GSM signal:

Steadily lit, no blinking: Excellent or good signal  
Slow blinking: Medium signal  
Rapid blinking: Poor signal

#### OUT1 and OUT2 status LEDs (4)

The OUT1 and OUT2 status LEDs constantly show the status of the respective outputs: **on:** output enabled  
**off:** output disable

#### Output buttons (5)

On the front of the interface there are two pushbuttons associated with the two outputs. Each time a button is pressed the status of the corresponding output is inverted: this allows manual on-site on/off switching.

#### Reset button (7)

Inside the interface there is a reset button (7) which, if pressed for one second, will restore the factory settings.

The reset function is useful should you forget the set password.

It is also possible to press the reset button without opening

the interface enclosure by inserting the tip of a screwdriver in the slot in proximity to the button, indicated in Fig. 3.

### DESCRIPTION OF COMMANDS

The commands for controlling the telephone interface are described in detail below. They represent the text to be written in the SMS message.

**All commands must be preceded by the password if the phone number the message is being sent from is not recorded in the contact list. The factory default password is "123456" and can be changed by means of a specific command.**

Example if not recorded: 123456 TURNON

Example if recorded: TURNON

### ⚠ WARNING

- When composing the text of command messages it is important to abide by the rules of syntax, including blank spaces.
- In the commands illustrated below, the \_ symbol stands for a blank space.
- Command texts can be either in capital or small letters.
- In the case of temperatures either a point or comma can be used as the decimal separator.
- Each SMS message may contain only one text command.

### TURNON-TURNOFF: activates or deactivates relay outputs

With the 'TURNON' and 'TURNOFF' commands you can activate or deactivate an output.

The message to be sent to the telephone interface is the following:

Activate OUT1: **TURNON OUT1**  
Activate OUT2: **TURNON OUT2**

Deactivate OUT1: **TURNOFF OUT1**  
Deactivate OUT2: **TURNOFF OUT2**

The name of the output can be omitted: in this case output OUT1 will always be turned on or off.

### TURNON TURNOFF

If alternative names have been associated with the 2 outputs via the 'NEWNAME' command - for example, the name "BURNER" has been associated with OUT 1 - more intuitive commands can be sent, like:

### TURNON BURNER TURNOFF BURNER

### ON/OFF SWITCHING VIA A CALL

If a phone number is recorded among the contacts, the status of output OUT1 can be switched simply by making a call from that number to the telephone interface. It will "hang up" on recognising the user and perform the operation while saving the cost of an SMS message.

In any case, even if SETREPORT is OFF, a message will be sent as notification that the status has been switched.

### STATUS: system status

The 'STATUS' command allows you to interrogate the interface in order to find out the current status of the outputs and inputs and obtain other information about the device.

The message to be sent to the interface is the following:

### STATUS

The interface will send a message reporting its current status.

Below is an example of a possible return message:

TEMP. 15.4C  
BURNER ON  
OUT2 OFF  
REGULATE 20.0C 11h59m  
ANTIFROST 5.0C

IN1 OPEN  
IN2 CLOSE  
SIGNAL GOOD  
CREDIT 124

**Note:** In the reply message the REGULATE, ANTIFROST and CREDIT lines will not be shown if the respective functions are not enabled.

### SETREPORT: Confirmation messages.

The telephone interface may be configured to respond to each command received with an SMS confirmation.

The message to be sent to the interface is the following:

To enable the sending of an SMS confirmation:

### SETREPORT ON

To disable the sending of an SMS confirmation:

### SETREPORT OFF

In the case of commands not associated with a specific response, an SMS confirmation with the following texts will be sent:

"Command executed"  
if the command was recognised and carried out.

"Error command"  
if the command was not recognised.

"Parameters error"  
if the parameters that follow the command were not recognised.

### SETPSW: Changing the password

Using the 'SETPSW' command you can change the password for sending commands via the telephone interface. The password may not exceed 6 characters in length.

It can be composed of alphanumeric characters with a distinction between capital and small letters.

### password attuale\_SETPSW\_nuova password

For example: 123456 SETPSW abCD12

"123456" was the old password, now "abCD12" becomes the new password.

### ADD: add a phone number to the contact list

With this command you can record your phone number in the contact list of the interface so that you can send commands without having to enter the password each time.

You will also have to record the phone number of the users you want alarm messages to be set to.

The contact list can contain up to a maximum of 10 names.

### ADD\_user name\_phone number

For example: ADD MARIO +393491234567

In this manner the user 'MARIO' associated with the phone number indicated will be memorised in the contact list.

It is important always to include the country calling code (+39 for Italy).

The name may be 14 characters long at the most.

### REMOVE: remove a number from the contact list

### REMOVE\_phone number

For example: REMOVE +393491234567

You can use this command to remove the phone number indicated from the contact list.

### CONTACTS: view the numbers recorded in the contact list

### CONTACTS

In response to this command the interface will send a message containing a list of all the recorded contacts. The name will be shown first, followed by the phone number.

If there more than 5 contacts, two SMS messages will be sent.

### REGULATE: Regulation of room temperature.

Thanks to an external sensor, the telephone interface allows you to regulate the temperature of the room it is installed in when the heating mode is enabled.

Using the 'REGULATE' command you can set the temperature and period of time (in hours) during which you want the temperature to be regulated.

The temperature can be set within the range of 0.0°C .. 32.0°C, whereas the time can be set from 1 to 24 hours. The regulation function is always performed via OUT1 and therefore a heating device (burner) must be connected to that output.

### REGULATE\_temperature\_time

The room temperature must be expressed in °C. The value can be expressed with or without the decimal, while the regulation time must be expressed in hours.

### For example: REGULATE 20 12 or REGULATE 20.0 12

The two examples given are equivalent and will result in the room temperature being regulated to a setpoint of 20.0°C for a period of 12 hours.

If the interface is configured to send a confirmation message (SETREPORT ON), it will respond to the REGULATE command with the return message of the STATUS command.

To end the regulation period earlier than planned you can send a 'TURNON OUT1' command (see 'TURNON-TURNOFF' command) or manually change the status by means of the pushbutton on the front of the interface.

### ANTIFROST: Enables the Antifrost function

When the antifrost function is enabled, the interface will activate output OUT1 if the room temperature falls below the set antifrost temperature (range 0.0°C .. 18.0°C). This serves to protect both the room and the HVAC system.

In order for the function to work, a heating device must be connected to OUT1 and an external temperature sensor must obviously be connected as well.

### ANTIFROST\_temperature

The room temperature must be expressed in °C; the value may be expressed with or without the decimal.

### For example: ANTIFROST 5

Enables the antifrost function on OUT1 with a threshold of 5°C. If the interface is configured to send a confirmation message (SETREPORT ON), it will respond to the ANTIFROST command with the return message of the STATUS command.

### ANTIFROST OFF: Disables the Antifrost function.

### ANTIFROST OFF

Disables the antifrost function and turns off OUT 1.

Alternatively, to disable the antifrost function you can send a 'TURNOFF OUT1' command (see 'TURNON-TURNOFF' command) or manually change the status by means of the pushbutton on the front of the interface.

### CALIBRATE: Sensor offset

If for any reason the room temperature measurement is not satisfactory, it is possible to correct it by means of the CALIBRATE command, which allows you to set a temperature offset of up to ±5.0°C, to be added to the actual room temperature reading.

The message must be composed as follows:

### CALIBRATE\_offset temperature

For example: **CALIBRATE 3,2**

3.2°C will be added to the room temperature measured by the sensor.

### CREDIT: Credit low warning.

With the CREDIT command it is possible to set the amount of

credit present in the SIM card and consequently receive an SMS warning message when the credit is about to run out. Credit must be expressed in the form of available SMS messages. The number of available SMS messages is calculated by dividing the credit in Euros of the SIM card by the cost of sending a single SMS message. The maximum number of SMS messages that can be set is 9999.

### CREDIT\_number of available SMS

For example: **CREDIT 300**

Enables the function and sets a remaining credit of 300 SMS. The interface keeps track of the remaining credit, decreasing the total by one unit each time an SMS message is sent. When the credit level falls below 10, a warning message will be sent: "**Warning credit is less than 10 SMS**".

In order for this function to be effective, you must remember to reset the credit level every time you recharge the SIM card.

### CREDIT OFF: disables the CREDIT function

To disable the credit warning function, send a message containing the following command:

### CREDIT OFF

### NEWNAME: Personalising the name of outputs and inputs

Using this command you can assign an alternative name to the 2 inputs and 2 outputs to make your commands more intuitive.

The two relay outputs of the interface are called OUT1 and OUT2, whereas the 2 inputs are called IN1 and IN2.

The message to be sent to the telephone interface must be worded as follows:

### NEWNAME\_input/output\_alternative name

For example: **NEWNAME OUT1 BURNER**  
**NEWNAME OUT2 CHILLER**  
**NEWNAME IN1 PUMP**  
**NEWNAME IN2 WINDOW**

The alternative name may be up to 10 characters long and can also be used in the ALARM and MESSAGE commands.

The alternative names defined with NEWNAME will be used in responses to the STATUS command and can also be used in the place of OUT1 and OUT2 to specify the output in a turnon/turnoff command.

### ALARM MANAGEMENT

The telephone interface can be configured to send SMS alarm messages. Each time an alarm event occurs, a message will be sent to all the users in the contact list, specifying the type of fault that has occurred.

The 'ALARM' command allows you to set the operating mode to be associated with each individual alarm and the ON/OFF status.

Below is a description of the various types of alarms and the syntax to be used in the message should you wish to change the current configuration. When an alarm is configured, if 'SETREPORT' is enabled (ON), an SMS message specifying the alarm configuration status will be sent.

### INPUTS ALARM

When this type of alarm is configured, the interface will monitor the status of the contacts connected to inputs IN1 and IN2.

Should there be a change in the status of the input as previously configured, the interface will send an SMS alarm message to all the users in the contact list.

### ALARM\_input\_status\_time

Input: IN1

Status: IN2  
OPEN  
CLOSE

Time: nel range 1 .. 255 secondi (s) o minuti (m)

Example: **ALARM IN1 OPEN 3 s**