

Table 2: Device parameters factory configuration.

P01	0	P08	0	P15	10.0	P22	17	P29	33
P02	0	P09	0	P16	30.0	P23	30	P30	66
P03	3	P10	1	P17	0.0	P24	40	P31	100
P04	3	P11	0	P18	0.0	P25	2.0	P32	0
P05	0	P12	0.0	P19	3.0	P26	2.0		
P06	0	P13	10.0	P20	0	P27	0		
P07	0	P14	30.0	P21	0	P28	0		

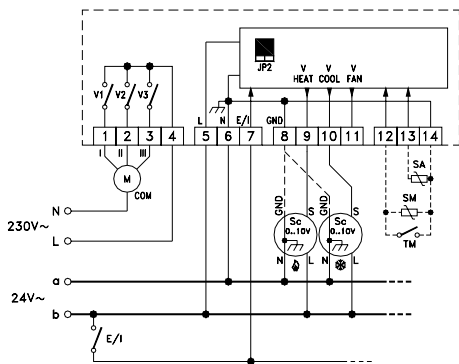

Fig. 7: Wiring diagram for pipes system with two 24V-actuators.

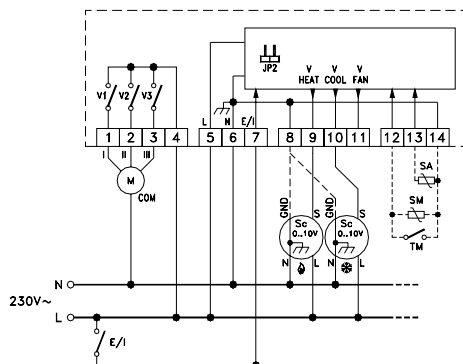

Fig. 8: Wiring diagram for pipes system with two 230V-actuators.

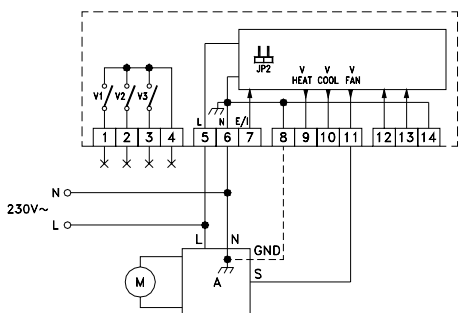

Fig. 9: Wiring diagram for proportional control of the fan by an external motor drive unit.

Explanation:

- VHeat: 0..10V hot signal output
- VCool: 0..10V cold signal output
- VFan: 0..10V fan signal output
- Sc: 0..10V servo-actuator
- SA: Room sensor
- SM: Supply water sensor
- TM: Cutoff bimetallic thermostat
- M: Fan motor
- E/I: Remote Heat/Cool signal
- A: Motor drive unit
- JP2: 230/24V~ selection

In the view of a constant development of their products, the manufacturer reserves the right for changing technical data and features without prior notice. The consumer is guaranteed against any lack of conformity according to the European Directive 1999/44/EC as well as to the manufacturer's document about the warranty policy. The full text of warranty is available on request from the seller.

FAN COIL CONTROLLER WITH DISPLAY AND 0..10V OUTPUT



- Completely configurable for any type of heating-cooling FCU needs
- Automatic control of fan motor with relays or proportional output
- Type P or P+I regulation with 0..10V actuators control
- Differentiated Set-Point range in Cooling and Heating
- Special functions: Economy, Dirty Filter Warning, Window Contact
- Remote Heating-Cooling selection input
- User selectable voltage (230V~ or 24V~)

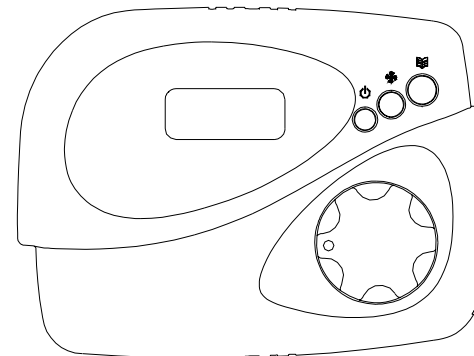

Fig. 1: Overall appearance

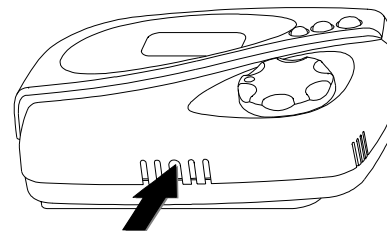

Fig. 2: Plastic cover opening slot.

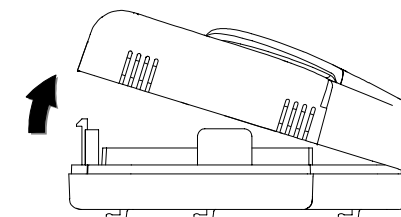

Fig. 3: How to remove the plastic cover.

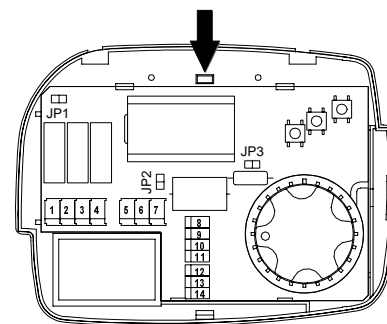

Fig. 4: Internal view.

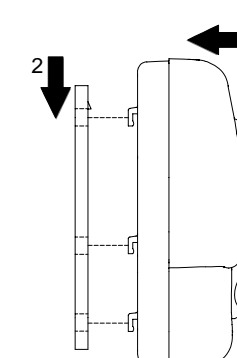

Fig. 5: How to snap the thermostat on its plate.

Introduction

This digital controller (Fig. 1) is intended for temperature regulation in environments equipped with fan-coil heat-cool exchangers. The device proportionally controls the opening of valves with P or P + I algorithm in order to adjust the room temperature in the most suitable way. The output for fan control can be a three speeds (3 relays) or 0..10V as well as valves. Temperature acquisition can be performed either with the internal sensor or with an external one (optional).

Operation

The commands available for the user are three pushbuttons and the set-point knob.

'On/Off Key

This button is used to turn on and off the controller: when the controller is turned off the display does not show the temperature, yet some symbols could still be turned on to show the active outputs.

'Fan Speed key

This button, when depressed once, makes the display show the current fan speed: this figure will be shown for a few seconds. After that the current room temperature will be displayed again. When this button is depressed several times the fan speed is changed according to the following cycle:



where F11, F12 and F13 mean the three 'Fixed' fan speeds meanwhile AUT mean the 'AUT'omatic fan speed.

More precisely F11 means the lowest speed, F12 the medium speed and F13 the fastest. Therefore when the controller is set on one of the three mentioned speeds, the fan will be activated when necessary at that (fixed) speed. Whenever the automatic speed is set instead, the controller will activate the fan at a speed as much high as the difference between the desired room temperature against the current one.

In case the controller is configured to drive the fan motor through the 0..10V proportional output, again it will be possible to set fixed speeds which rate can be configured as desired (P29 P30 P31).

'Menu key

This button is used to change the display readout mode: when depressed once it makes the display show the set-point temperature. In case the controller is configured to show the supply pipe water temperature, this value will be displayed with a further button depression. In case the controller is configured to perform the 'Economy' function, this will be activated with a further action on this button. If 'Economy' was already active instead, depressing the button will result in changing the mode into 'Normal'.

When changing the readout, the controller informs the user about the parameter shown according to the following table:

TR	Room (ambient) temperature
SET	Set-point temperature
TP	Supply pipe water temperature
ECCO	Economy function Active

When the button is depressed several times the display readout cycles across the above mentioned temperatures. After a few inactivity seconds the display readout returns to the room temperature. In case the 'Economy' mode is activated, the controller always returns showing the 'ECO' message and the temperature is not visible.

Knob

The regulation knob allows the user to adjust the desired room temperature (set-point). The knob has no range printed: whenever it is moved the display readout jumps to the set-point temperature, thus showing the value currently setting. Even in this case after a few inactivity seconds the display readout returns to the room temperature.

Display

The regulator features a 3-digits LCD display to show temperatures and settings. All temperatures shown must be intended in Celsius degrees (centigrade).

On the display there are also some symbols which report about the current state of the outputs: fan and valves.

The fan symbols are related to the fan motor state: when all fan symbols are turned off then the fan is actually off, meanwhile when some of them are turned on the state of the fan respects the following table:

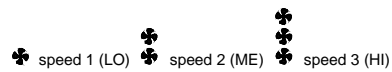

In case the controller is configured to drive the fan through the 0..10V proportional output, likewise more symbols will be turned on as faster the fan speed gets. Besides the 'fan' symbols, the display can show two further symbols, which identify that the relevant valve is open.

Symbols are turned on even if the proportional valve is in a minimum opening position.

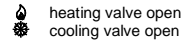

Symbols can also be flashing, to explain that the relevant output should be turned on, yet it is temporarily disabled by another function.

As an example, outputs are disabled in the following situations:

- The cut-off thermostat is inhibiting the fan;
- The window contact is inhibiting the regulation;

Heating/Cooling selection

Cooling (summer) or heating (winter) modes are selected by keeping the 'mode' button depressed for some seconds, until the display shows one of the following words (meaning the current mode):

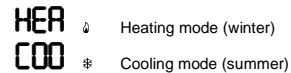

Then, by pressing the 'speed' button, the user can actually choose the desired mode, cycling between heating and cooling. Depressing any of the other buttons results in quitting the menu and in the storage of the preferred configuration data.

In case the controller is configured for remote or automatic heating/cooling selection it is not allowed to enter in the heating/cooling selection menu.

Installation

To install the controller follow these directions:

1. Remove the plastic cover pressing (with the help of a tool like a screwdriver) the plastic tooth located in the lower slot as indicated in Fig. 2 raising, at the same time, the front cover as indicated in Fig. 3.
2. Unmount the plate fixed at the controller back by pressing the plastic tooth shown in Fig. 4 and, at the same time, pull the plate to the bottom until it becomes free from the plastic base.
3. Fix the plate to the wall through the two holes using the correct distance between holes (60 mm or 83 mm).
4. Mount the controller base on the wall plate by fitting the base teeth in the relevant holes on the wall plate, then apply a slight pressure towards the bottom until the plate fixing tooth snaps (Fig. 5).
5. Make electrical wirings passing the cables through the rectangular opening and according to the 'Wiring' section.
6. Close the controller coupling the two plastic teeth located in the upper back part of the plastic cover with the relevant holes of the base. Then, after ensuring that the knob is correctly coupling to its hole, apply a slight pressure on the front cover towards the wall until the closing plastic tooth snaps.

Wirings

This controller can be powered either with 230V~ or with 24V~. The controller is factory configured by default for a 230V~ operation with the relevant jumper in position JP1. For the 24V~ operation it is necessary to move the jumper from position JP1 (Fig. 4) to position JP2 (Fig. 4). As shown in Fig. 6 terminals 5 and 6 are provided for power supply. In case of 230V~ mains power it is mandatory to respect Live and Neutral indication.

At terminal 7 an input for remote heating/cooling selection is made available. In case this function is not used, the same terminal input can be used to activate the 'Economy' mode.

A remote temperature sensor can be wired to terminals 13 and

P07	Fan output type	0	Three speed relays	1	Proportional	2	Proportional reversed action				
P08	Supply water sensor input	0	Do not show temperature	1	Show temperature	2	Bi-metallic contact	3	Window contact	4	Reversed window contact
P09	De-stratification	0	Never	1	Cooling only	2	Heating only	3	Always		
P10	On/Off state at power up	1	Last	2	Always on	3	Always off				
P11	Room temp. sensor	0	Internal	1	External						
P12	Room temperature correction (offset) (°C)	-5.0 .. 5.0									
P13	Heating set-point knob lower limit (°C)	5.0 .. 35.0									
P14	Heating set-point knob upper limit (°C)	5.0 .. 35.0									
P15	Cooling set-point knob lower limit (°C)	5.0 .. 35.0									
P16	Cooling set-point knob upper limit (°C)	5.0 .. 35.0									
P17	Anti-freeze threshold temperature (°C)	0 .. 15.0									
P18	Economy reduction (°C)	0.0 .. 10.0									
P19	Neutral zone width (°C)	1 .. 11.0									
P20	Fan delay at turn-on (seconds)	0 .. 600									
P21	Fan delay at turn-off (seconds)	0 .. 600									
P22	Changeover lower threshold (°C)	0 .. 24									
P23	Changeover upper threshold (°C)	26 .. 48									
P24	Cut-off thermostat threshold temperature (°C)	0 .. 99									
P25	Heating proportional band (°C)	0.9 .. 8.0									
P26	Cooling proportional band (°C)	0.9 .. 8.0									
P27	Heating integrative time (minutes)	0 .. 30									
P28	Cooling integrative time (minutes)	0 .. 30									
P29	Fan MIN speed (F11)	1 .. 100									
P30	Fan MED speed (F12)	1 .. 100									
P31	Fan MAX speed (F13)	1 .. 100									
P32	Dirty filter warning time (x 100 hours)	0 .. 50									
END											

P29 P30 P31: when the fan is driven by the proportional output, these parameters define the speed regimes associated to the fixed speeds settings F11 F12 F13. When the fan is driven by relays these parameters are not used.

P32: This parameter sets the time after which the 'Dirty Filter Warning' is shown; it can be set in the range 0..50 x 100h. As an example '10' means that the warning will be shown after 10 x 100 = 1000 hours of fan operation. When set to 0 the function is disabled.

Room temperature correct acquisition

For a correct temperature acquisition it is mandatory to remember and apply the following tips:

- In order to have an accurate room temperature acquisition the controller must be installed far from heat sources, airstreams or cold walls (thermal bridges). When the remote sensor is used in conjunction with the controller, then this note is to be applied to the remote sensor itself.
- When a remote sensor is used, do not use the same duct for signal wires and power wires, as the temperature reading accuracy could be impaired. Wirings can be usefully made with bipolar screened cable, whose screen is only wired at the

regulator side (terminal 14) with 1,5 mm² minimum cross section and 15 m. maximum length.

- In the normal operation with internal sensor, the controller conditions the signal acquired according an exclusive algorithm designed to compensate for the heat generated from its internal components. From this derives that the temperature value displayed at turn-on can be actually lower than the real one. This must be considered a normal behaviour: anyway in some minutes this difference should decrease down to zero.
- In case the controller should drive with its outputs large loads (whose current is close to the maximum rated value) it might happen that the internal components temperature raise. This temperature increase could in turn influence the room temperature acquisition when the internal sensor is used. This problem is not evidenced when the remote temperature sensor is used.
- When, for any reason, the room temperature accuracy is considered unsatisfactory (due to the above mentioned reasons), it can be corrected with parameter P12.
- When the controller is powered with 230V- it is mandatory to respect the live and neutral (L and N) position during wiring.

Fig. 6: Example of proportional outputs control in a 4-pipes system with neutral zone.

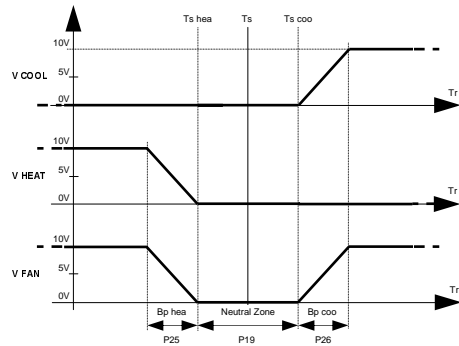

V COOL: cooling valve proportional output
V HEAT: heating valve proportional output
V FAN: fan proportional output
Tr: room temperature
Ts: set-point temperature (knob)
Ts hea: heating set-point temperature
Ts coo: cooling set-point temperature
Bp hea: heating proportional band
Bp coo: cooling proportional band

In the diagram it is assumed that outputs are configured for proportional direct action and that any integrative action is not taken into account. Likewise a 2-pipes system valve output (heating valve output) would be driven at the same way, in this case Ts (knob set-point temperature) would coincide with Ts hea when in heating mode and Ts coo when in cooling mode.

Table 1: Installer configuration

Summary of the parameters involved in the 'installer' configuration.

CON					
P01	System type	0	2-pipes system	1	4-pipes system
P02	Heating/cooling selection	0	Manual	1	Automatic
				2	Remote
				3	Reversed remote
P03	Heating regulation	1	Valves only	2	Fan only
				3	Valves and fan
P04	Cooling regulation	1	Valves only	2	Fan only
				3	Valves and fan
P05	Heating output type	0	Direct action	1	Reversed action
P06	Cooling output type	0	Direct action	1	Reversed action

14. The selection between internal or remote sensor is made through the configuration procedure. Terminals 12 and 14 feature a further input to which several types of sensor can be wired in order to accomplish special functions: the user can wire a supply water temperature sensor for performing the 'changeover' and/or 'cut-off thermostat'; as an alternative a bimetallic thermostat can be wired here, still for a 'cut-off thermostat' function; further a window contact can be wired. **Note:** some limitations exist for the window contact: please read carefully the 'WARNING' section. The preferred sensor type can be set in the configuration menu.

As previously mentioned this regulator is suitable for three-speeds fan-coils driving. The speed selection is performed through three relays whose outputs are available at terminals 1, 2 and 3. Terminal n. 4 is the common for these three relays. In Fig. 6 is shown how to wire the fan. Outputs for the motor (terminals 1 to 4) are voltage free and insulated with respect to the remaining circuitry of the regulator. For this reason the regulator can be powered with a low voltage (24V-) and, at the same time, it can drive a higher voltage motor (230V-), as visible in Fig. 7.

As an alternative the fan motor can be proportional driven with the same algorithm used for the valves, if it is available a "motor drive unit" with a 0..10V input and capable of driving the fan motor at its output. In this case the proportional output at terminal 11 must be used with its reference ground terminal 8 to control the input of the motor drive unit, as visible in Fig. 9. By modifying P07 parameter the user choose to either use relays or the proportional fan output.

The regulator can drive one or two 0..10V proportional actuators according to whether the system is a 2 or 4 pipes.

Hot water valve output is available at terminal 9, while cold water output is at terminal 10. In case of 2 pipes system, one valve handles both hot and cold water and in this case the control signal is the hot one at terminal 9.

For all the proportional 0..10V signals (fan and valves) the reference ground is available at terminal 8, also notice that reference ground is electrically connected to supply terminal 6 (Neutral). To wire actuators follow Fig. 7 diagram if they are 24V supplied, instead if they are 230V supplied, wire them following Fig. 8 diagram. Usually 0..10V actuators have only three wires since ground of input signal is internally connected to one of the supply wire (Neutral).

In this case it is not necessary to wire terminal 8 (ground of output signal) since the actuator use as ground the Neutral supply wire, pay attention that this one is wired to terminal 6.

Technical features

Power supply: 230V- -15% +10% 50Hz

or

24V- -15% +10% 50Hz

Power absorption: 1,2W

Room temperature

Regulation range: 5.0 .. 35.0 °C (configurable)

Sensor type: NTC 4.7kΩ @ 25°C ±2%

Precision: ± 1.0 °C

Resolution: 0.1 °C

Display temp. range: 0.0 .. 40.0 °C

Supply pipe temperature

Sensor type: NTC 4.7kΩ @ 25°C ±2%

Precision: ± 2 °C in the 20 .. 50 °C range

Resolution: 1 °C

Display temp. range: 0 .. 99 °C

Differential: 2 °C

Proportional outputs

Signal range: 0..10 V DC

Signal precision: ±0.26 V DC

Minimum actuator impedance: 6 Kohm

Regulation

Proportional band: 0.8 .. 8.0 °C

Integrative time: 1 .. 30 min

Neutral zone: 1.0 .. 11.0 °C

Fan motor contact rating: 3A @ 250V- cosφ=1

Remote sensor (optional): Cod. STL NTP A150

Protection grade: IP 20

Operating temperature: 0 .. 40 °C

Storage temperature: -10 .. +50 °C
 Humidity limits: 20 .. 80 % RH (non condensing)
 Case: material: ABS V0 self-extinguishing
 color: cover: signal white
 base: light grey
 buttons: light grey
 knob: light grey
 Size: 129 x 96 x 37 mm (W x H x D)
 Weight: 223 gr

⚠ WARNING

- The supply water sensor must be installed in a way that it can acquire the correct water temperature even in case the flow is stopped by the valve itself.
- Wiring the same remote temperature sensor to more than one controller is not allowed.
- All remote sensors, bimetallic contact and window contact must have a galvanic insulation against earth as well as against the mains power.
- In case preceding two directions are not respected an irreversible product damage can follow.
- All remote sensors, bimetallic contact and window contact must be double insulation (or reinforced insulation) rated in case they are accessible to people.
- In case the reinforced insulation of the preceding point cannot be obtained, power the regulator with a 24V- low voltage in full compliance with the safety standards.
- The appliance must be wired to the electric mains through a switch capable of disconnecting all poles in compliance with the current safety standards and with a contact separation of at least 3 mm in all poles.
- Installation and electrical wirings of this appliance must be made by qualified technicians and in compliance with the current standards.
- Before wiring the appliance be sure to turn the mains power off.

Appendix

Supply pipe sensor

This controller features an input for a sensor mounted on the water supply pipe: when this sensor is used the controller can automatically understand whether it should be working in 'cooling' mode or in 'heating' mode: this function is called 'changeover' and it is based on the water temperature.

The water temperature is also used to perform the 'cut-off thermostat' function: this means that when the controller is in heating mode but the water in the pipe is too cold then the fan is automatically stopped until the water temperature goes above a set threshold.

At this input can also be wired a bimetallic thermostat for the same 'cut-off' function. In case this function is not required, the same input can be used to wire a window contact, which will stop the temperature regulation whenever in the room the window will be open. When the regulation is inhibited by the window contact, symbols related to the active outputs will flash on the display.

Note: there are some limitations for the window contact use: please read carefully the 'WARNING' section.

Temperature acquisition

This controller acquires both the room temperature and the supply water temperature in the fan-coil exchanger with NTC type sensors. The room temperature is acquired and displayed with the above mentioned resolution in the range 0 .. 40°C.

In case the room temperature falls outside the operating range, the display shows "Or" (out of range). In case the sensor acts as an open or a short circuit the display shows "EEE" (error): no regulation is performed in this situation and all outputs are set as inactive.

The controller features an internal temperature sensor but an input for a remote sensor is also available. Through parameter P11 in the 'installer configuration' one of these two sensors is selected for the regulation purpose. The supply water temperature in the fan-coil is acquired through a remote sensor and can be displayed with 1°C resolution in the 0 .. 99°C range. In case the acquired temperature falls outside the operating range mentioned, the display will show the letters "Or" (out of range). In case the sensor acts as an open circuit or a short circuit the display will show the letters "EEE" (error) and all functions related with this

data are not performed. In case the system doesn't require the supply remote sensor the user is allowed not to install and wire it. For what is related to the supply sensor activation please refer to the explanations in paragraph 'Cut-off temperature function'.

Cut-off temperature function

The cut-off temperature function is used to inhibit the fan operation whenever, but only in heating mode, the supply water is not hot enough. In order to enable this function a supply pipe sensor (or even, alternatively, a bimetallic thermostat) must be wired to the proper terminals. In case the supply pipe sensor is used, the relevant threshold for this function (i.e. the value for the controller to decide when the supply water is hot enough) is defined by parameter **P24**.

In case this function is not needed parameter **P24** can be set to a very low value (as an example '0').

On the other hand when for this function a bimetallic thermostat is used, it is mandatory to set parameter **P08** to value '2': in this case the fan will be enabled only when the thermostatic contact is closed. When this type of thermostat is used the supply temperature cannot be displayed, nor the automatic changeover function can be performed. Please refer to the section 'Installer Configuration' to set the parameters related to the above described functions. When the fan is stopped by the cut-off temperature function the 'fan' symbols on the display flash.

Economy function

The 'Economy' function allows to temporarily set an energy saving mode through a reduction of the actual set-point temperature by a step (configurable) when in heating mode, or increasing it by the same step when in cooling mode.

The value for this reduction step is set with parameter **P18**: when this is set at 0.0 Economy function is actually disabled. Economy saving mode is started from the menu button, as explained in the 'Operation' section. In case the remote heating/cooling mode is not configured, terminal 7 can be used to start the 'Economy' function from remote even at the same time on several different regulators. When the wire connected at this terminal is linked with the Live voltage of power supply, the function is started; the same function is terminated when this terminal is left unconnected (open). The regulator detects the state changes of the terminal, not the level itself, therefore it is always possible to override the Economy state set by terminal 7 with a manual action on the menu button.

When Economy mode is active, being an energy saving mode, the fan motor speed will be limited to the lowest one (first) or at the value set in **P29** in case of fan proportionally driven.

Dirty filter warning function

Fan-coils and other devices including a fan are often equipped with a filter for the air in the suction path, which needs a periodical maintenance and cleaning or replacement. This regulator can warn the user when the maintenance has to be made, provided the 'Dirty filter warning' function has been enabled.

The function is enabled by setting the time-to-maintenance value (each unit means 100 hours) in parameter **P32**: the regulator will count the operating time of the fan and when the value stored in **P32** (x 100 hours) is reached it will warn the user through a message on the display.

In this situation the regulator shows on the display, in place of the room temperature, the two words **FIL-TER** alternating. If any key is depressed the warning disappears and the display returns to its normal mode. Whenever the regulator is turned off and then on again, the warning will reappear. This is an extremely useful function for the maintenance service, which can easily check whether the filter needs to be cleaned.

In order to reset the warning and the relevant time-counter, once the cleaning has been made, just keep depressed the speed button for at least 10 seconds, until the regulator will confirm to have reset the warning by showing again the words **FIL-TER**.

Temperature regulation

This device can drive in a proportional way both valves and fan in order to control room temperature with the highest comfort and energy saving. Nonetheless each different environment needs a different set for some parameters in order to get an accurate regulation.

Parameters devoted to the regulation accuracy are:

- Proportional band: **P25** and **P26**

- Integrative time: **P27** and **P28**

For each of the settings two parameters are available, because

the user is allowed to set different values for heating and cooling mode. Proportional band, measured in °C, is intended as the difference between set-point and room temperature which is needed to fully open the regulating valve.

The narrower the proportional band, the fastest is the regulator to counteract temperature variations in the room.

Yet a value for this parameter too 'narrow' can result in room temperature oscillations or system instability. A value too 'wide' could result in the impossibility to reach the set-point temperature in the room. When the integrative time is set to zero, no integral action is made and therefore the regulation is purely proportional (P type). When an integrative time different from zero is set the resulting regulation is made of a Proportional plus an Integral action (P + I type). The smaller the integrative time, the greater the influence of the integral action and vice-versa: with a greater integrative time the resulting integral action is softer.

A too soft or null integral action could result in the impossibility to reach the set-point temperature, meanwhile a too strong integral action could possibly generate oscillations in the room temperature. It is necessary to adjust these parameters according to the actual environment in which the regulator is installed for the purpose of the best possible regulation accuracy.

The fan is driven in a proportional way with the same regulation of valves except when a fixed speed is set F11..F13. With fixed speed, the fan can be only turned off or turned on at the fixed speed, there is no proportional regulation, actually it becomes an ON-OFF regulation with a 0,2°C hysteresis.

When the fan is driven by three relays (three speeds), the distance between a speed stage and the next is set at about one third of the proportional band value and the switching is performed with a 0,2°C hysteresis. Except when fan is driven with 0..10V output and the speed is set to automatic, the fan will be turned on at about 15% opening of the valve, thus to avoid high fan speeds when the valve is still almost closed.

Installer configuration

The 'installer' configuration is used to setup the controller in order to get the best regulation in conjunction with the type of heating/cooling system installed. In order to enter the configuration menu, turn off the controller, then keep depressed both buttons "on/off" and "menu" together for some seconds, until the word "CON" (configuration) appears on the display. From this state on, each time the "menu" button is depressed a different parameter is displayed, identified with a 'P' followed by a number, i.e. from **P01** to **P32**. The end of configuration is indicated by the word "End": if now the 'menu' button is depressed once again the configuration is saved in a non-volatile memory and the controller jumps into the normal operation mode. In case the 'on/off' button is depressed, at any time the controller exits from the configuration menu, without saving the changes. When parameters are examined, if the 'speed' button is depressed once, the actual value of the parameter is displayed.

When the value is shown press again the 'speed' button to change the value. Parameters from **P01** to **P11** can be set by pressing several times in sequence the 'speed' button until the desired value is reached. The following parameters, being variable in a wider range, can be modified by first pressing once the 'speed' button, so that the 'modify parameter' mode is entered, then turning the knob to modify the desired value. Upper and lower limits for the knob regulation are redefined each time according to the actual parameter allowable range. In order to disable the access to configuration menu to unauthorized users, an internal jumper, **JP3**, (shown in fig. 4), can be removed; after this any attempt to enter in the configuration menu will result in an error message.

Configuration parameters explanation

All parameters used in the installer configuration are shown in Table 1 and explained in the following.

P01: System type selection.

2 pipes system: when configured for a two-pipes system the controller drives one valve only, wired at the 'heating' output terminal, both when heating and when cooling, as the same valve is going to control either hot or cool water flow.

4 pipes system: when configured for a four-pipes system the controller drives both valves outputs in order to activate either hot water or cooling one according to the actual requirements of the controlled environment.

P02: This parameter sets the way the controller switches from the

cooling mode (summer) to the heating mode (winter) and vice versa.

The switching can be either manual or automatic:

Manual: The user manually sets the heating or the cooling mode.

Automatic: The controller automatically selects the switching from the heating to the cooling mode or vice-versa.

This automatic operation is different according to the system type set with parameter **P01**.

If the system is a 4-pipes one, the controller operates with neutral zone thus activating the heating or cooling according to the set-point temperature. In case of a 2-pipes system the controller operates a changeover according to the supply water temperature. When the supply water temperature is low (that is below the threshold set with parameter **P22**) the controller switches to cooling mode. On the opposite side, when this temperature is high (that is above the threshold set with parameter **P23**) the controller switches to heating mode. In case the supply temperature is neither too low nor too high the operating mode is kept unchanged, but it still can be changed manually. When the supply water sensor is not installed or is not properly working then no automatic selection is performed and the manual switching is only allowed.

Remote selection: In a building with several regulators all inputs (terminal 7 of each regulator) can be wired together and driven by a remote signal coming from the furnace room. In case the furnace leaves the remote signal 'floating', all regulators will be set into heating mode, meanwhile when remote signal is connected to the mains 'Live' all regulators will be set into cooling mode.

In Fig. 6 is shown a wiring example for a remote heating/cooling selection.

Reversed remote selection: same as before but with reversed logic: terminal 7 floating sets cooling mode, while terminal 7 connected to mains 'Live' sets heating mode.

P03 and **P04**: these parameters set which outputs are controlled. When in heating mode parameter **P03** is used, when in cooling mode **P04** is used instead. Each parameter sets whether temperature is to be regulated through valves, fan, or both. When valves only is chosen, the fan will be turned on even after temperature has reached the set-point; when fan only is chosen the valve will always be opened even after temperature has reached the set-point.

P05 and **P06**: these parameters set which type of proportional action is desired on the valves' output.

Direct action means that the output gives 0V to close the valve, while it gives 10V to open the valve. Instead if it is set to **Reversed action**, the output gives 10V to close the valve, while it gives 0V to open the valve.

P07: This parameter sets if the fan is driven by the three relays (terminals 1..4) or by the proportional output (terminal 11). The proportional output is not suitable to directly drive a motor, it is meant to be connected to a "motor drive unit" which in turns drive the motor. It is also possible to choose that the output is driven with reversed action then, likewise valves' output, it would give 0V to turn on the fan at maximum speed, and 10V to turn it off.

P08: This parameter sets the type of sensor connected to the supply water temperature input at terminals 12 and 14. When set to value 0 or 1 a temperature sensor is expected for the acquisition of water temperature. When 1 is set, the temperature value is also shown over the display, according to the user choice. In case 0 is set, the information coming from the temperature sensor is still used for the regulation purpose, even if its value is never shown.

Value '2' means that the device connected to terminals 12 and 14 is a bimetallic contact, which will act as cut-off thermostat only. When the parameter is set to '3' a window contact can be wired at terminals 12 and 14: when this contact is closed the regulation is carried out as usual, meanwhile when it is left open regulation is stopped. Note: some limitations exist for the window contact: please read carefully paragraph 'WARNING'. If this parameter is set to '4' a 'reversed' logic is adopted for the window contact: open means usual regulation, closed means regulation stopped.

P09: This parameter enables the 'de-stratification' function in the environment. With this function the fan is turned on, at its lowest speed, for about 2.5 minutes every 15 minutes. The function is only active when the fan should be turned off according to the room temperature.

P10: In case of a black-out the controller remembers its last state

and, as soon as the power is applied again it restarts with the same settings (on/off, heating/cooling, etc.).

Anyway, in some situations it is requested for the controller to restart from a fixed state (i.e. always from off or from on).

This can be accomplished by setting parameter **P10** to '2' (always restart from 'on') or '3' (always restart from 'off').

P11: Room temperature sensor selection.

This parameter sets whether the temperature sensor used for regulation has to be the one internal to the controller or the external one wired to the terminals 13 and 14.

P12: With this parameter a slight correction (offset) for the acquired room temperature can be set. Actually it could happen that in some installations, due to the sensor location (either internal or external) the temperature readout is not accurate. By changing the value of this parameter the display readout can be corrected of the equivalent amount (in the -5.0 .. +5.0°C range), being this a value which is actually added to the acquired temperature value.

P13 and **P14**: These two parameters set the temperature limits for the set-point knob range when in heating mode.

In details **P13** is the lower limit, it can be configured in the range 5.0 .. 35.0°C while **P14** is the upper limit, whose value can be configured starting from the actual **P13** value until 35.0°C.

The maximum range is then 5 .. 35°C and it can be easily modified according to the installation needs.

P15 and **P16**: These two parameters set the temperature limits for the set-point knob range when in cooling mode according to the same logic as those in the former step.

In case the heating/cooling settings are modified, the temperature limits for the set-point knob are automatically modified in turn. When the 'neutral zone' operation is selected, these two parameters will not be used and only the **P13** and **P14** values will be taken into account.

P17: This parameter defines an anti-freeze temperature (in °C), that is a minimum temperature which is maintained in the room even when the regulator is turned off (with the on-off button).

Regulation according to this temperature will only take place when the regulator is set in heating mode; the fan speed will be limited to the lowest one. Setting the value to 0.0 disables the anti-freeze function.

P18: This value defines the entity of a temperature reduction step (in °C) used to perform the 'Economy' function. The actual set-point is therefore reduced (when in heating mode) or raised (when in cooling mode) by this step, once the 'Economy' function is made active. When this is set at 0.0 the 'Economy' function is actually disabled.

P19: In case the controller is configured for a neutral zone operation this parameter determines the relevant amplitude in the range 1.0 .. 11.0°C. This value has to be intended centered across the temperature set with the knob. In case the controller is configured for a different operation this parameter is not used.

P20: This parameter allows to set a delay time (in seconds) from the valve opening to the fan turn-on, in order to allow some time for the heat exchanger to heat-up or cool-down.

P21: This parameter allows to set a delay time (in seconds) from the valve closing to the fan turn-off, in order to allow some time for the heat exchanger to dissipate the residual heat.

P22 and **P23**: These parameters set the thresholds for the automatic changeover operation: in case this function is not performed these two parameters are not used. Parameter **P22** is the lower threshold and can be modified in the range 0 .. 24°C, meanwhile **P23** is the upper threshold in the range 26 .. 48°C.

P24: This parameter sets the threshold for the cut-off temperature function: this function is active in heating mode when a supply water sensor is wired at the proper terminals. In case this function is not desired the parameter should be set to '0'.

P25 and **P26**: These parameters set the proportional band amplitude (in °C) when in heating and in cooling mode respectively. In fig. 6 is graphically shown the effect of proportional band on the output.

P27 and **P28**: these parameters are used to set the integrative time respectively for regulation in heating mode and in cooling mode. When set to zero no integral action is performed.