

## DRPA83 Wireless Receiver

for heating and cooling plants

The DRPA83 is the receiving part of the wireless system for temperature control in rooms or offices. It features one SPDT relay output which is driven from radio commands received from a thermostat or a chronostat transmitter.

This system is definitely the best solution in all those buildings where no wires can be laid between the thermostat and the heating-cooling room. The thermostat transmitter issues some radio commands directed to the receiver unit DRPA83 M01 according to the need for heating or cooling in the room where the thermostat is actually located. These 'radio commands' are then received and decoded by the receiver, which is usually installed in the room where the burner or the chiller are located. In the receiver unit the relay output turns-on or off according to the regulations needs and can be connected to a valve which will control the flow of hot/cold water in the relevant room heating/cooling system.



### FEATURES

- Self-learning of the thermostat's address by pressing an internal Button
- One channel with SPDT relay output
- Night reduction capability by connecting an external clock switch
- Compliant with directives EEC 89/336, 73/23 and 93/68, 99/05

Model Types	Model	Description
	<b>DRPA83M01</b>	DRPA83M01 Wireless Receiver for Heating and Cooling Plants
<b>Technical Data</b>	Power Supply	230V~ -15% +10% 50Hz
	Power Consumption	0.5W
	Contact Rating	6A @ 250V~ cos3=1
	Frequency	868.35 MHz
	Modulation Type	ASK
	Antenna Type	Internal
	Max. Distance from Transmitter	30 m indoor (depending on the environment)
	Storage Temperature	-10°C .. +50°C
	Operating Temperature	0°C .. 40°C
	Protection Class	IP30
	Humidity Limits	20% .. 80% rH (non condensing)
	Enclosure	Material: ABS V0 self-extinguishing
	Colour	Signal white (RAL 9003)
	Agency Compliance	EEC 89/336, 73/23, 93/68, 99/05
Size	85W x 85H x 31D mm	
Weight	0.16kg	

**Operating Description**

The two-colour led in the frontal panel (1) Fig. 1 may turn-on and be either red or green. On start-up, when the receiver unit DRP A83 M01 is supplied the led (1) flashes in a sequence “green-red-green-red” to show the correct working of the device. Afterwards the led becomes active according to its normal functioning and the receiver starts to decode the signals issued by the transmitter as its normal working.

In the normal functioning the red side of the led (1) displays the status of the output relay:

- Red side turned-on means relay output ON
- Red side turned-off means relay output OFF

The green side of the led (1) can turn-on at the same time of the red one's, and in the normal working it flashes rapidly giving an information about the quality of the signal received.

One flash: a command has been received and the signal is strong, the communication is reliable.

Two flashes: a command has been received, the signal is still sufficient but the communication might be corrupted by occasional disturbances.

Three flashes: a command has been received from a transmitter in which is set an address different from the one memorized in the receiver, and so the command has been ignored.

If more than one transmitter were installed in the close area, an indication of this kind has to be considered normal. If the green side led flashes once and sometimes twice, the received signal has to be considered good. In the normal working, the DRP A83 M01 receiving unit continuously monitors the status of the communications with the thermostat to recognize a possible malfunction of the system. Particularly if no command is received from the transmitter in 90 minutes, (i.e. if the battery of the transmitter is flat) the output will be put in an “alarm status”. When in “alarm status” the output relay is turned-off and the red side of the led (1) displays this status blinking. The “alarm status” ends as soon as a command is received correctly.

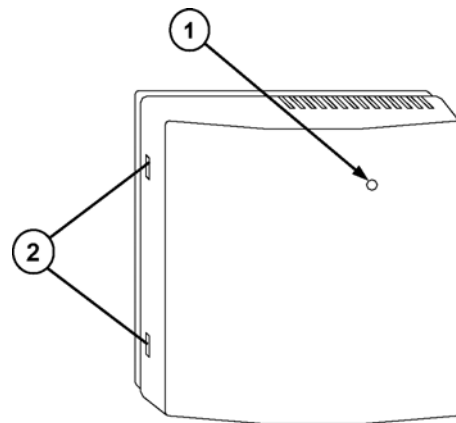

Fig. 1

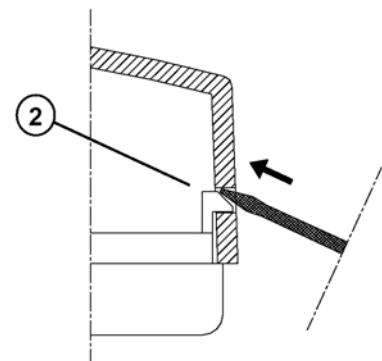

Fig. 2

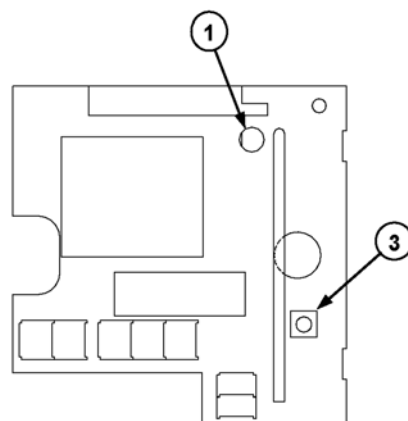

Fig. 3

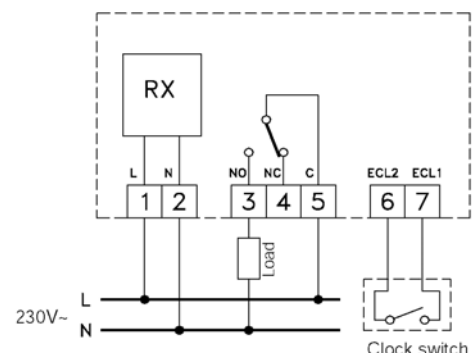

Fig. 4

**Mechanical Construction and Installation**

In Fig. 1 is visible the external appearance of the DRP A83 M01.

- (1) Two-colour led  
     red side: output status  
     green side: quality of communication
- (2) Side holes for cover removing.

To install the receiving unit it is necessary to access to the internal parts. When opening the case always ensure that the unit is disconnected from the 230V~.

To open the plastic case, remove the frontal panel using a small screwdriver to drive the plastic teeth (2) shown in Fig. 1 and Fig. 2. Apply a light pressure with the screwdriver between the tooth and the hole in the plastics, but do not push directly on the tooth in order not to break it. The Fig. 2 represents the plastic box' section and it shows how to handle the screwdriver correctly.

In Fig. 3 is shown the receiver's internal layout, and the location of the self-learning button (3).

The mechanical installation consists in fixing the DRP A83 M01 on a wall by two screws, using the holes with distance between axes of 60 mm.

While working with tools in the screw holes, be careful not to damage the internal circuits or any other component. Once the electrical installation has been completed, close the plastic case by carefully positioning the frontal panel so that the hole matches the led (1), then slightly press the panel in order to make the four plastic teeth (2) snapping.

**System set-up**

To be allowed to install more thermostats in the close area and to use multi-channel wireless system, every thermostat and chronostat has its own address selectable in a 8 way dip-switch. So thermostats with different addresses can work at the same time without interfering each other and controlling different zones. In order to memorize the address of the thermostat we want to receive the commands, a simple set-up procedure has to be made.

**Step 1.** Set an address in the thermostat, it can be chosen randomly, but attention must be paid if more than one thermostat is installed in the same building or in the close area, the addresses must be different.

**Step 2.** Turn-on the thermostat in the "Test" mode. In this modality it continuously issues a On and Off command every 3 seconds. See the relevant documentation for further information. Locate temporarily the thermostat close to the receiver in order to easy the address self-learning procedure.

**Step 3.** After opening the case of the DRP A83 M01 wire it to the 230V~ power supply. At the start-up the led (1) will perform the sequence "green-red-green-red".

**Step 4.** Execute the self-learning procedure by pressing the button (3) Fig. 3 for one second, until the led (1) turns-on green. Now the receiver waits for a command, and as soon as it receives ones from the thermostat transmitter in "Test" mode, it learns his address and memorizes it. When correctly memorized the led (1) executes another sequence "green-red-green-red", and then the receiver returns to its normal working. The address is memorized in a nonvolatile way, so it is retained and used in the normal working even after a power supply failure. If mistakes occur, it is possible to execute the self-learning procedure again.

After the self-learning has been done, the receiver's output will be driven by the thermostat in "Test" mode, so the relay output will be turned-on and off every 3 seconds. Locate temporarily either the receiver and the thermostat in the desired final position. Keeping on with the "Test" mode check out the signal and ensure it is still sufficient: the output relay should turnon and off every 3 seconds. Check out the green led (1) flashes as explained before.

If the signal is too weak the relay will get stuck always on or always off. We recommend to try out different location of the receiver, much better performances might be obtain even lightly moving the device. It is important to install the receiver and the transmitter as far as possible from metal sheets or reinforced cement walls which could weaken the radio signals.

**Electrical Installation**

This section explain how to wire correctly the DRP A83 M01, please read carefully the following and see Fig. 4 which shows the internal terminals and how they are internally connected.

Terminals 1 and 2 are the unit supply input, wire it to the 230V~, terminal 2 is the Neutral. Terminal 3, 4, 5 are the SPDT relay output contacts. In Fig. 4 is shown how to connect a load using the normally open contact. In this way the load will be supplied when the output is active. Terminals 6 and 7 are inputs for an external clock switch. If the wireless thermostats used in the wireless system provide a 3°C reduction (such as DTP A80 BC), by connecting an external clock switch the system will be able to regulate the temperatures with a programmed reduction of 3°C. To enable the programmed reduction, just wire terminals 6 and 7 to the output contacts of an electronic or electromechanic clock switch.

**Electrical Installation  
Cont'd...**

When the clock contacts are closed, the system will regulate according to the comfort setpoint, when they are open the regulation will be performed according to the 3°C reduced setpoint.

Note that if you do not connect any clock, the inputs 6 and 7 are always open, so this will make the system perform the reduced setpoint regulation, however in the thermostat can always be manually selected the comfort setpoint.

In this case there will not be a programmed reduction, but you will be able to manually select the comfort or reduced setpoint from the thermostat panel selector (in the DTP A80 BC the sun or moon position, see thermostat documentation for more information).

If you desire the receiving unit never work with any reduction, just wire terminals 6 and 7 together. In case the receiver is used in conjunction with either a thermostat without 3°C reduction or a chronostat, it will never regulate with any reduction regardless the state of the clock input.

**Maintenance**

No particular maintenance is required for this product. Periodically check for the good quality of the received signals. In case the signal from the thermostat is too weak or absent, the red side led (1) blinks. This could happen if the transmitter battery is flat.

**Troubleshooting**

<b>TROUBLE SHOOTING</b>		
<b>SYMPTOM</b>	<b>PROBABLE REASON</b>	<b>REMEDY</b>
The receiver seems to be completely 'dead'.	230V~ power supply is not present.	Check for the correct supply of the device. Normally the led (1) remains turned-off, but at the start-up it flashes in a sequence "green-red-green-red" to show the correct working of the appliance.
The red side of the led (1) Fig. 1 in the frontal panel blinks.	The output is in "alarm status" because its relevant transmitter does not work well or the signal is too weak.	Check the battery of the relevant transmitter. See its documentation for more information.
When the transmitter is working in "Test mode" the receiver does not activate the relay. The green side of the led (1) quickly flashes three times.	Signals issued by the transmitter are correctly received but the address set on the dip-switch of the transmitter does not match the address memorized in the receiver.	Execute the "self-learning" as explained in the "System set-up" section.
When the transmitter is working in "Test mode" the receiver does not activate the relay. The green side of the led (1) remains always turned-off.	Signals received are too weak for the receiver to correctly decode the command.	Reposition the transmitters and/or the receiver. Take care of avoiding positioning them close to metal screens or electrical disturbances sources. Spend some time to find the best orientation.

**WARNING !**

- To determine the right position ensure that the radio signals transmitted are correctly received by the receiving unit.
- To adjust properly room temperature, install the thermostats far from heat sources, airstreams or particularly cold walls (thermal bridges).
- The appliance must be wired to the electric mains through a switch capable of disconnecting all poles compliant to the current safety standards and with a contact separation of at least 3 mm in all poles.
- Installation and electrical wirings of this appliance must be made by qualified technicians and in compliance with the current standards.
- Before wiring the appliance be sure to turn the mains power off.

Notes: In the view of a constant development of their products, the manufacturer reserves the right for changing technical data and features without prior notice. The consumer is guaranteed against any lack of conformity for 24 months from the time of delivery, according to the European Directive 1999/44/EC. The full text of guarantee is available on request from the seller.