

DLP200M 2 Relay Module

for Heating and Cooling Plants

The DLP 200 M is a relay module for activation of loads (namely thermal actuators or circulators) in wireless heating or cooling plants for rooms or offices.

It features 2 independent channels which in turn might be linked up to the same number of transmitters (thermostats). This system is definitely the most comprehensive solution in all those buildings where no wires are allowed/practical between the thermostat and the heating cooling room.



FEATURES

- Up to 2 different channels
- LED indication for relay outputs and signal strength
- Possibility to be connected in chain to a DLP600M unit
- Compliant with directives EEC 89/336, 73/23 and 93/68, 99/05

Model Types	Model	Description
	DLP200M	DLP200M 2 Relay Module
Technical Data	Power Supply	230V~ -15% +10% 50Hz
	Power Consumption:	2 W
	Contact Rating:	3A @ 250V~ cos3=1
	Maximum Total Load Current	6A
	Motor Contact Rating:	3A @ 250V~ cos3=1
	Internal Circuit Protection Fuse	0.5A
	Loads Protection Fuse	Self-resetting thermal type
	Protection Class	IP30
	Operating Temperature	0°C .. 40°C
	Storage Temperature	-10°C .. +50°C
	Humidity Limits	20% .. 80% rH (non condensing)
	Enclosure	Material: ABS V0 self-extinguishing
	Colour	Signal white (RAL 9003)
	Agency Compliance	EEC 89/336, 73/23, 93/68
Size	130W x 100H x 60D mm	
Weight	0.57kg	

Operation

Every single thermostat transmitter issues some 'radio commands' directed to the active antenna according to the need for heating or cooling in the room where the thermostat is actually located, as well as to its own set-up.

These 'radio commands' are then received by the active antenna, which is installed in a convenient position in the room where the boiler or the chiller is located. The active antenna then sends the digital data through a data cable to the relay module, so that only the relay matched with its relevant transmitter/thermostat switches ON and OFF according to the regulation needs. Every relay output can be connected to a valve which will control the flow of hot/cold water in the relevant room heating/cooling system.

While working, the DLP 200M unit continuously monitors every channel state to recognize a possible malfunction of the transmitters. Particularly if a channel state is not updated by a command from the relevant transmitter in 90 minutes, this channel will be put in an "alarm status". When in "alarm status" the relevant LED output blinks, and an alarm condition action is performed. The alarm condition action can be chosen from switching OFF the output or to always provide a 30% power. Setting this function will be explained in the next sections.

Mechanical Description

On the front panel of the DLP 200 M, visible in Fig. 1, six LEDs are found:
 - the 'power' green LED (2) turns on when the unit is supplied with 230V~.
 - the 2 red channels' LEDs (3) which display the relevant output state.
 - the received signal strength LEDs (4)

To install the receiving unit it is necessary to have access to the enclosed parts.

When opening the enclosure **always ensure** that the unit is disconnected from the 230V~.

To open the enclosure, unscrew the four screws (1) Fig. 1: after this the cover is easily removed. The internal layout is shown in Fig. 2. **JP1** (6) and **JP2** (7) are the bridges to be removed when using an auxiliary power supply for the loads. **F1** is a 1A fuse protecting the loads (8). The dip-switch for the "Option" settings is shown (9). The set of pushbuttons (10) for the self-learning of the transmitters codes are also highlighted in Fig. 2.

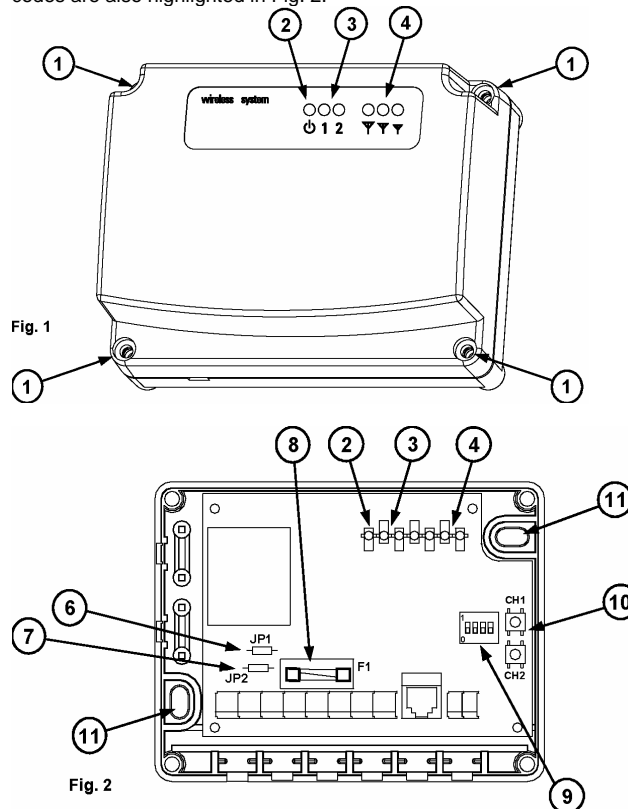

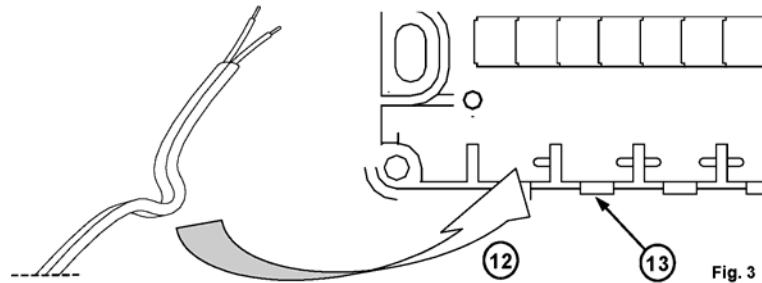

Wiring Diagram

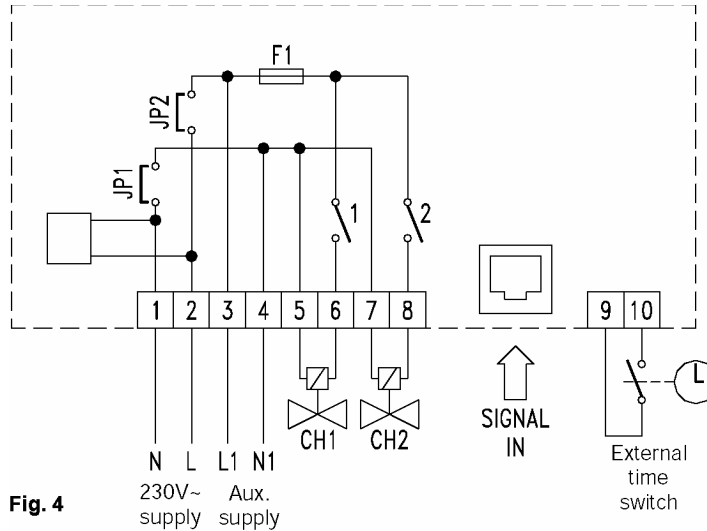

Fig. 4

System Setup

The receiving system is composed at least of an 'active antenna DAE A83' and a 'module relay DLP200M'. Wire carefully the power supply and the outputs at the DLP 200M side. Then with the unit turned off, insert the cable interconnecting the active antenna and the relay module into the relevant sockets (see Fig. 4). The cable coming from the active antenna, or the output signal of a DLP 600 M unit if the system requires a chain of relay modules must be inserted in the socket labeled as 'SIGNAL IN' on the board.

Double check every connection and proceed as follows (it is assumed that you already set-up the transmitter codes as described in the transmitter instruction sheet):

1. Switch ON the relay module: the LEDs will be flashing for a while during the start-up sequence.
2. Turn on one transmitter and put it into 'test mode' (this means that it will issue a continuous sequence of 'on' and 'off' commands, every 3 seconds).
3. In order to 'match' every single transmitter with the desired receiving channel a simple set-up procedure has to be made: the desired channel on the receiver must 'learn' the address code of the relevant transmitter. This operation is really very simple thanks to the self-learning capability of the DLP 200M. Whichever is the transmitter code, the DLP 200M detects a correct code and stores it in a non-volatile memory. Press for one second the pushbutton relative to the channel which you want to 'link' to the active transmitter: The self-learning procedure is initiated and the channel LED flashes quickly. When a correct code sequence is detected it is stored in memory and then the channel LED flashes slowly three times. After the self-learning the output relay will soon start switching ON and OFF every 3 seconds, following the transmitter commands.
4. Test each thermostat transmitter with the 'test' function for location and functionality in order to be sure that the received signal is strong enough for a good reception: check also the "signal strength indicator". Do not test more than one transmitter at the same time to avoid malfunction due to signals overlapping.
5. When the overall behaviour is satisfactory proceed with the final mechanical and electrical installations.

Notes

The DLP 200M can show which channels has been assigned to an address code and which has not. During the start-up sequence, when the unit is first powered, the LEDs in the front panel (3)(4) Fig. 2, blink three times. Afterwards the unit switches on for a while only the active channels' LEDs i.e. the channels that has been assigned to an address code.

The 'non active' channels' LEDs remain off. If the system needs only one thermostats and so it does not need the two channels outputs, it is important to keep the unused channels 'non active' by not assigning them any address code. The unit will ignore the 'non active' channel being not wired to any valve.

Setting a channel as 'non active'

In case an active channel output has to be turned to 'non active', its address memorization can be 'erased' by the following procedure:

1. Press the desired channel's button (10) Fig. 2 and keep it pressed.
2. The relevant LED flashes quickly, then after a few seconds it will flash slowly three times.
3. Release the button.
4. Disconnecting the power supply for a while will reset the DLP 200M so during the start-up the unit will show which channels are still active.

When a channel is 'non active', it will be ignored in all the functions, and its relevant relay will stay always switched off, whichever the received signals are.

Signal strength indicator

The DLP 200M is equipped with a signal strength indicator which simplifies the installation and troubleshooting of the whole system. It is made of three colored LEDs located on the right upper part of the receiver case, see (4) Fig. 1 and Fig 2. When a signal burst is received the three LEDs turn OFF for a while. After this the LEDs turn ON indicating the received signal's strength. The received signal's strength will remain displayed by the LEDs until another burst is received. The meaning of the LEDs is described as follows:

- **Green:** the received signal is very good and the communication is reliable.
- **Yellow:** the received signal is still sufficient but the communication is not so reliable, it might be corrupted by occasional disturbances.
- **Red:** the received signal is poor and therefore the communication is definitely not reliable. Check for location of both the transmitter and the active antenna connected to the unit.

Two LEDs at once may turn on to indicate a midway strength condition. All three LEDs are switched ON together when a signal is received which address is not programmed in any unit's channel. All three LEDs are displayed ON for a while, then the previous signal's strength indication is recalled.

In order to correctly understand the signal strength, observe the indicators (LEDs) for a couple of minutes. If the green LED switches ON and sometimes even the yellow one's switch ON, then the received signal is good. When the received signal is not sufficient the green LED does not switch ON at all. The signal is too poor and the communication is not reliable when the red LED switched ON often. If the signal strength is not acceptable try to change the position of the transmitter or the receiving antenna. Remember that they must be placed far from metal sheets or reinforced cement walls which could weaken the radio signals.

Outputs control and special options

When the DLP 200M relay module is correctly powered, the green LED (2) Fig. 1 is switched ON. At the start-up to perform a LED test, the LEDs in the front panel (3)(4) (5) Fig. 2, blink three times. Afterwards the unit displays for a while the active channels and then they become active according to their function. The unit starts receiving signals from the thermostat transmitters as its normal operation. While working the DLP 200M continuously monitors every channel state to recognize a possible malfunction of the transmitter. If a transmitter does not send any signal in 90 minutes, for example if its battery is poor, the relevant channel will be put in an "alarm condition". When in "alarm condition" the relevant LED output blinks, and the channel output is switched OFF. An optional setting is available to always provide a 30% ON and 70% OFF power in the "alarm condition". If one or more channels is 'non active' they will not be monitored and their LEDs will never blink. To set 30% power function and other modalities perform a set-up of the option dip-switch (9) Fig. 2.

OPTION DIP-SWITCH	1. 30% Power:	0 In case of alarm condition always switch OFF the output. 1 In case of alarm condition always provide the output a 30% of the power.
	2. Valve Exercise:	0 Valve exercise never performed. 1 If an output is not switched ON in 23 hours (stays continuously OFF), the output is switched ON for 3 minutes.
	3. Not Used:	0 Always keep it to '0'. 0 The clock switch signal is not put on the chain connection. 1 The clock switch signal is shared through the chain connection with other units.
	4. Clock share:	

The 30% option is useful in cold areas where not providing any power to a heating system may cause a damage. In case of alarm status in one or more outputs, if the 30% power option is enabled, that output will be continuously turned on for 3 minutes and then turned off for 7 minutes, this to provide a minimum power with 30% duty.

When in alarm status, the relevant led of the channel (3) Fig. 1 blinks. It can blink in two different ways depending on the state of the output relay. If the output is turned off it stays off and flashes for a while, instead when the output is turned on the led stays on and turns off for a while. Valve exercise option is useful when the valves connected to the channel's outputs should not kept turned off for a long time to guarantee their working life. When valve exercise option is enabled the receiving unit automatically activate each valve at least 3 minutes every day.

The "clock share" option allows a chain of DLP 200 M and DLP 600 M connected together to use a unique comfort/reduction signal provided by a clock switch wired in one of the unit. When the "clock share" option is enabled the clock switch signal of the unit is available through the data connection for the other units. Other units without the clock switch wired will use the data connection signal when their "clock share" option is enabled. In case your system does not require any special option, leave all the option switches in the "0" position.

Mechanical Installation	<p>The mechanical installation consists in fixing the DLP 200M on a wall or a frame with two screws. Once removed the unit front panel, fix the case using the two screw holes shown in Fig. 2 (11). While working with tools close to the electronic parts, be sure that they are disconnected from the 230V~, and be careful not to damage the circuits or any other component.</p> <p>Once the system is set up and the electrical installation has been completed, fix the enclosure cover back on. The cables should be bended as shown in Fig. 3 and inserted in the cable holder (12) in order to close the case and hold the cables correctly. When using a cable holder remove with a tool the plastic tooth (13) Fig. 3 to open the cable intake. Position the panel onto the case and fix the five closing screws (1) Fig. 1.</p>
Electrical Installation	<p>This section explain how to wire correctly the DLP 200 M: please read carefully the following and see Fig. 4 which shows the internal terminals layout and how they are internally connected. Terminals 1 and 2 are the unit power supply input: wire them to the 230V~, ensuring terminal 1 is the wired to the Neutral. The electronic circuitry is internally protected with a self-resetting thermal fuse, meanwhile the loads are protected by a 0.5A fuse F1 (8) Fig. 2. Terminals 3 and 4 are the auxiliary load supply, terminals 5 to 8 are the two loads outputs.</p> <p>When delivered the module is internally bridged to the power supply line (230V~) and therefore is capable of supplying directly the loads wired to its terminals 5 to 8 as shown in Fig. 4. In this case the auxiliary supply in 3 and 4 must not be connected and the loads are driven with 230V~ voltage. If the loads need to be driven with a different voltage (as an example a 24V~ load) the receiving unit must be slightly modified as following.</p> <ol style="list-style-type: none"> 1. Cut the wire bridges JP1 and JP2 labeled as (6) and (7) Fig. 2 and completely remove them. This will remove the 230V~ supply to the internal bus for the loads. 2. Wire to terminals 3 and 4 (Fig. 4) an external power source (as an example a transformer with 24V~ output). 3. Wire to terminals 5 .. 8 the loads you have to drive. These loads must be rated for the voltage that you are supplying at terminals 3 and 4. 4. Check the loads protection fuse F1 (8) Fig. 2, it must be rated according to the maximum loads current (see following).

The user must take into account the power consumption of the loads and be sure that the external power source is capable of delivering the total power needed in the worst case (when all loads are switched ON). As an example if you are using 2 electrothermal zone valves rated 6W each at 24V~ then you need at least an external transformer with an output of 24V~ and 6W x 2 valves = 12W rated power (a safety margin in power of 10% in excess is highly recommended: in the previous example this means that the transformer should be rated at least 15W).

The loads protection fuse **F1** (8) Fig. 2 is provided with a rating current of 0.5A, it should guarantee a good protection for all kinds of 230V~ loads.

If 24V~ loads are to be driven, we recommend to replace the fuse **F1** (8) Fig. 2 with a higher rating current one, please ask your local distributor for more information.

Terminals 9 and 10 (Fig. 4) are the inputs for an external clock switch. If the wireless thermostats used in the wireless system provide a 3°C reduction (such as DTP A80 BC), by connecting an external clock the system will be able to regulate the temperatures with a programmed reduction of 3°C. To enable the programmed reduction, just wire terminals 9 and 10 to the output contacts of an electronic or electromechanic clock. When the clock contacts are closed, the system will regulate according to the comfort set point, when they are open the regulation will be performed according to the 3°C reduced set point.

Note that if you do not connect any clock, the inputs 9 and 10 are always open, so this will make the system perform the reduced set point regulation, however in the thermostat can always be manually forced the comfort set point. In this case there will not be a programmed reduction, but you will be able to manually select the comfort or reduced set point from the thermostat panel selector (in the DTP A80 BC the sun or moon position; see thermostat documentation for more information).

If you desire the receiving unit never work with any reduction, just wire terminals 9 and 10 together. All thermostats with no 3°C reduction will never work with any reduction regardless the state of the clock inputs.

In the plug labelled "Signal IN" must be connected the cable coming from the active antenna. The DLP 200 M can also be connected in a chain fashion to a DLP 600 M so that all the units of the chain will use the same active antenna. In case the unit is to be connected in a chain fashion, an interconnection cable must be plugged between the 'SIGNAL OUT' plug of a DLP 600 M and the 'SIGNAL IN' plug of the DLP 200 M.

See the wiring examples in Fig. 5 and Fig. 6. Consider that up to 10 relay modules can be wired in chain through the 'SIGNAL OUT' and 'SIGNAL IN' plugs. The DLP 200 M must be the last unit in the chain since it does not have a 'SIGNAL OUT' plug connector on the board. For the same reason more DLP 200 M units cannot be connected together in a chain.

When the DLP 200 M is connected in a chain, it shares its pump signal with other units through the data connection, therefore it is possible to have a circulator pump relay on a DLP 600 M which will be driven according to the state of the channels of all the modules connected in the chain included the two channels of the DLP 200 M.

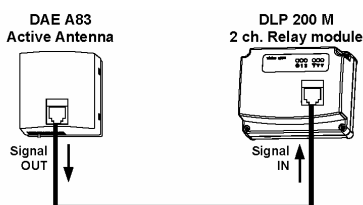

Fig. 5 Data cable wiring for a system based on one active antenna DAE A83 and one relay module DLP 200 M.

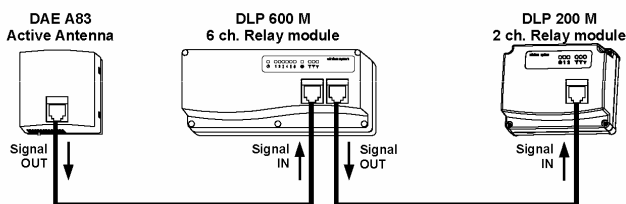

Fig. 6 Data cable wiring for a system with one active antenna DAE A83, one relay module DLP 600 M and one relay module DLP 200 M.

Maintenance

No particular maintenance is required for this product. Periodically check for the good quality of the received signals. In case the signal is too weak or absent in one or more channels, the relevant output led blinks. This could happen if the transmitter battery is flat. In case the fuse is blown (see trouble shooting) remove power supply, check the electrical plant and the valves connected. Replace the blown fuse with a model of identical type and ratings.

WARNING !

- To adjust properly room temperature, install the thermostats far from heat sources, airstreams or particularly cold walls (thermal bridges).
- The appliance must be wired to the electric mains through a switch capable of disconnecting all poles compliant to the current safety standards and with a contact separation of at least 3 mm in all poles.
- Installation and electrical wirings of this appliance must be made by qualified technicians and in compliance with the current standards.
- Before wiring the appliance be sure to turn the mains power off.

Troubleshooting

TROUBLE SHOOTING		
SYMPTOM	PROBABLE REASON	REMEDY
The module seems to be completely 'dead'. No leds are turned on at all.	Power supply is not present.	Check for the correct supply of the device.
	The thermal fuse is triggered.	Turn off power. Wait at least 15 min. then re-apply power. (see also "Electrical installation" section).
The module works properly, the channel's leds and relays turn on but the valves connected are stuck, always turned off.	The loads fuse is blown.	Be sure that power supply and auxiliary supply are removed, then check for the integrity of the fuse F1 (8) Fig. 2 and replace it with a new one of the correct type and ratings (see also "Electrical installation" section).
One or more channel's led (3) Fig. 1 in the front panel of the receiver blinks.	Those channels are in "alarm status" because their relevant transmitters do not work well.	Check the battery of the relevant transmitters. See their documentation for more information.
When a transmitter is working in test mode the receiver does not activate any relay. In the signal strength indicator all three leds turn on.	Signals issued by the transmitter are correctly received but they do not match any of the addresses stored in the relay module.	Perform the 'self-learning' procedure as indicated in the 'System set up' section for the channel you want to be 'linked' to that transmitter.
With a transmitter working in test mode the module does not activate any relay. The leds of the signal strength indicator are always off or always displaying the last strength indication.	The module gets no data from the SIGNAL IN plug..	Check for the correct wiring of the data cables. The cable connected to the SIGNAL IN plug must come from the active antenna or the SIGNAL OUT plug of another DLP 600 M unit.
When a transmitter is working in test mode the receiver does not activate any relay. The leds of the signal strength indicator display a weak signal, red turned on, or both red and yellow turned on.	Signals received are too weak for the module to correctly decode the command.	Reposition the transmitters and/or the active antenna. Take care of avoiding positioning them close to metal screens or electrical disturbances sources. Spend some time to find its best place and orientation.

Notes: In the view of a constant development of their products, the manufacturer reserves the right for changing technical data and features without prior notice. The consumer is guaranteed against any lack of conformity for 24 months from the time of delivery, according to the European Directive 1999/44/EC. The full text of guarantee is available on request from the seller.